

**Onan**

**Commercial Mobile Power**

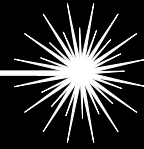

# **Operator's Manual**

**HDKBB**

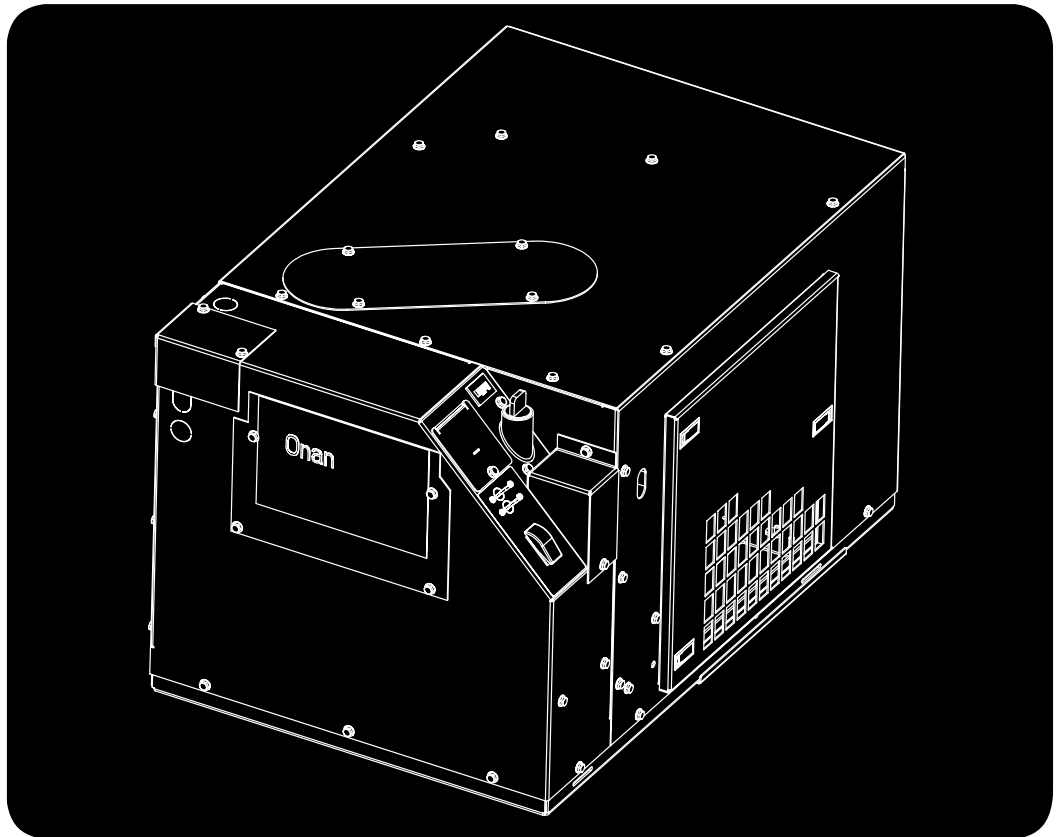

**California**

**Proposition 65 Warning**

**Diesel engine exhaust and some of its constituents are known to the State of California to cause cancer, birth defects, and other reproductive harm.**

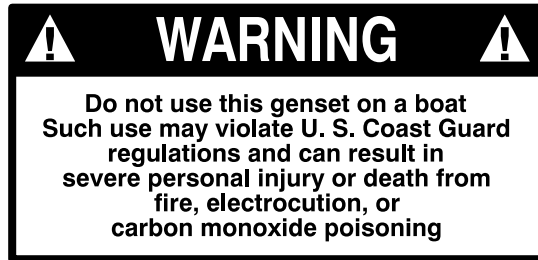

**Supplement:** 981-1049

**Date:** 09/04

**Insert with-**

<b>Manual Number (Date):</b>	981-0173 (08/04)	981-0174 (08/04)	981-0540 (08/04)
	981-0170 (11/03)	981-0171 (11/03)	981-0526D (02/04)
	981-0166B (06/03)	981-0167B (06/03)	981-0535 (10/02)
	981-0161 (08/89)	981-0522B (07/99)	

**Purpose:** These instructions supplement the instructions for filling the engine cooling system found in the *Periodic Maintenance* sections of the Operator's and Service Manuals listed above.

**⚠ WARNING** *To prevent severe burns from hot coolant under pressure, carefully observe all of the Safety Precautions and Instructions in the Manual for handling and filling coolant.*

**Instructions:** Use a funnel when filling the cooling system through the fill opening (Figure 1) to prevent coolant from entering the vent hose and blocking the escape of air as the system fills. The system *will seem full when it actually is not* if the air cannot escape through the vent hose. If the vent hose does get blocked, pinch the overflow hose and blow the vent hose clear.

**⚠ CAUTION** *Coolant trapped in the vent hose will prevent the system from filling to its capacity, which can lead to serious engine damage.*

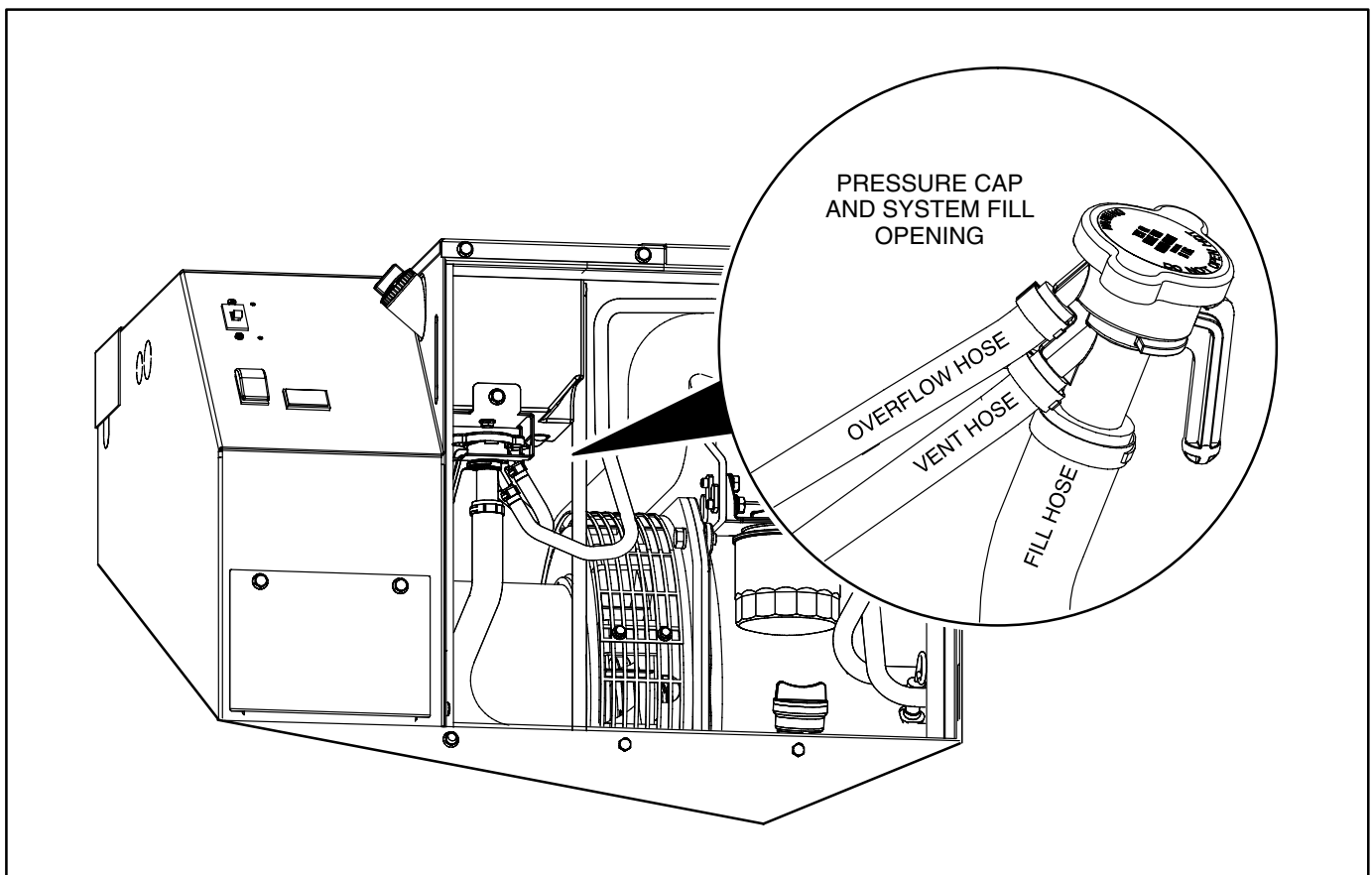

**FIGURE 1. TYPICAL COOLANT FILL OPENING WITH CONNECTED FILL, OVERFLOW AND VENT HOSES**

# Table of Contents

---

<b>SAFETY PRECAUTIONS</b> .....	2
<b>INTRODUCTION</b> .....	4
About this Manual .....	4
Model Identification .....	4
Fuel Recommendations .....	5
Engine Oil Recommendations .....	5
Starting Batteries .....	5
Typical Genset .....	5
Operator's Console .....	6
Remote Control Panel .....	7
<b>OPERATION</b> .....	8
Conducting the Pre-Start Checks .....	8
Priming the Fuel System .....	8
Starting the Genset .....	8
Stopping the Genset .....	8
Loading the Genset .....	9
Resetting Circuit Breakers .....	10
Connecting to Utility Power .....	10
Operating in Cold Weather .....	11
Operating in Hot Weather .....	11
Operating at High Altitude .....	11
Operating in Dusty Environments .....	11
Breaking in a New Engine .....	11
Exercising the Genset .....	11
Storing the Genset .....	12
<b>PERIODIC MAINTENANCE</b> .....	13
Conducting General Inspections .....	14
Checking Engine Oil Level .....	15
Changing Engine Oil and Oil Filter .....	16
Maintaining the Battery and Battery Connections .....	17
Replacing the Air Filter Element .....	17
Cleaning the Spark Arrestor .....	18
Replacing the Fuel Filter .....	19
Changing Coolant .....	20
<b>TROUBLESHOOTING</b> .....	22
<b>SPECIFICATIONS</b> .....	29
<b>EMISSIONS</b> .....	30
<b>HOW TO OBTAIN SERVICE</b> .....	31
<b>MAINTENANCE RECORD</b> .....	32

# Safety Precautions

---

Thoroughly read the OPERATOR'S MANUAL before operating the genset. Safe operation and top performance can only be obtained when equipment is operated and maintained properly.

The following symbols in this manual alert you to potential hazards to the operator, service person and equipment.

**⚠ DANGER** alerts you to an immediate hazard which will result in severe personal injury or death.

**⚠ WARNING** alerts you to a hazard or unsafe practice which can result in severe personal injury or death.

**⚠ CAUTION** alerts you to a hazard or unsafe practice which can result in personal injury or equipment damage.

Electricity, fuel, exhaust, moving parts and batteries present hazards which can result in severe personal injury or death.

## GENERAL PRECAUTIONS

- Keep children away from the genset.
  - Do not use evaporative starting fluids. They are highly explosive.
  - To prevent accidental or remote starting while working on the genset, disconnect the negative (-) battery cable at the battery.
  - Let the engine cool down before removing the coolant pressure cap or opening the coolant drain. Hot coolant under pressure can spray out and cause severe burns.
  - Keep the genset and its compartment clean. Excess oil and oily rags can catch fire. Dirt and gear stowed in the compartment can restrict cooling air.
  - Make sure all fasteners are secure and torqued properly.
- Do not work on the genset when mentally or physically fatigued or after consuming alcohol or drugs.
  - You must be trained and experienced to make adjustments while the genset is running—hot, moving or electrically live parts can cause severe personal injury or death.
  - Used engine oil has been identified by some U. S. state and federal agencies as causing cancer or reproductive toxicity. Do not ingest, inhale, or contact used oil or its vapors.
  - Ethylene glycol, used as engine antifreeze, is toxic to humans and animals. Clean up spills and dispose of used engine coolant in accordance with local environmental regulations.
  - Keep multi-class ABC fire extinguishers handy. Class A fires involve ordinary combustible materials such as wood and cloth; Class B fires, combustible and flammable liquid fuels and gaseous fuels; Class C fires, live electrical equipment. (ref. NFPA No. 10)
  - Genset installation and operation must comply with all applicable local, state and federal codes and regulations.

## GENERATOR VOLTAGE IS DEADLY

- Generator electrical output connections must be made by a trained and experienced electrician in accordance with applicable codes.
- The genset must not be connected to the public utility or any other source of electrical power. Back-feed could lead to electrocution of utility personnel and damage to equipment. An approved switching device must be used to prevent interconnections.
- Use caution when working on live electrical equipment. Remove jewelry, make sure clothing and shoes are dry, stand on a dry wooden platform or rubber insulating mat and use tools with insulated handles.

## ENGINE EXHAUST IS DEADLY

- Learn the symptoms of carbon monoxide poisoning in this manual.
- Never sleep in the vehicle while the genset is running unless the vehicle is equipped with a working carbon monoxide detector.
- The exhaust system must be installed in accordance with the genset Installation Manual.
- Engine cooling air must not be used for heating working or living spaces or compartments.
- Make sure there is ample fresh air when operating the genset in a confined area.

## DIESEL FUEL IS COMBUSTIBLE

- Do not smoke or turn electrical switches ON or OFF where fuel fumes are present or in areas sharing ventilation with fuel tanks or equipment. Keep flames, sparks, pilot lights, arc-producing equipment and all other sources of ignition well away.
- Fuel lines must be secured, free of leaks and separated or shielded from electrical wiring.

## BATTERY GAS IS EXPLOSIVE

- Wear safety glasses.
- Do not smoke.
- To reduce arcing when disconnecting or reconnecting battery cables, always disconnect the negative (-) battery cable first and reconnect it last.

## MOVING PARTS CAN CAUSE SEVERE PERSONAL INJURY OR DEATH

- Do not wear loose clothing or jewelry near moving parts such as PTO shafts, fans, belts and pulleys.
- Keep hands away from moving parts.
- Keep guards in place over fans, belts, pulleys, and other moving parts.

## FLAMMABLE VAPOR CAN CAUSE A DIESEL ENGINE TO OVERSPEED

Flammable vapor can cause a diesel engine to overspeed and become difficult to stop, resulting in possible fire, explosion, severe personal injury and death. ***Do not operate a diesel-powered genset where a flammable vapor environment can be created by fuel spill, leak, etc.*** The owners and operators of the genset are solely responsible for operating the genset safely.

# Introduction

## ABOUT THIS MANUAL

This manual covers the operation and maintenance of the HDKBB Series of generator sets (gensets). Study this manual carefully and observe all of its instructions and precautions. Keep this manual and the genset Installation Manual with the other vehicle manuals.

*Operation, Periodic Maintenance and Troubleshooting* provide the instructions necessary for operating the genset and maintaining it at top performance. The owner is responsible for performing maintenance in accordance with the PERIODIC MAINTENANCE SCHEDULE (Page 13). This manual also includes genset specifications, information on how to obtain service and information regarding compliance with emissions regulations.

**⚠WARNING** *This genset is not a life support system. It can stop without warning. Children, persons with physical or mental limitations, and pets could suffer personal injury or death. A personal attendant, redundant power or an alarm system must be used if genset operation is critical.*

## MODEL IDENTIFICATION

Be ready when contacting an Onan dealer for parts or service to provide the model and serial numbers on the genset nameplate. Figure 1 illustrates the nameplate and its location. The numbers in the gray boxes are typical model and serial numbers. Every character in these numbers is significant. (The last character of the model number is the specification letter, which is important for obtaining the right parts.) Record the model and serial numbers in the boxes in Figure 1 so that they are easy to find when you need them.

Genuine Onan replacement parts are recommended for best performance and safety.

**IMPORTANT ENGINE INFORMATION**

 Model No: 5.5HDKBB-2860A S/N: F000 123456 AC Volts: Amps: Fuel: Options:	CUMMINS POWER GENERATION 1400 73rd Ave. NE Minneapolis, MN 55432 Made in U.S.A. PH: kW: RPM: Bat: Wiring Diagram:	
---	---	--

Insulation - NEMA Class      Ambient

[The engine family designation, engine displacement, statement of compliance with applicable EPA and / or California emissions regulations appear in this block on the actual nameplate on the genset.]

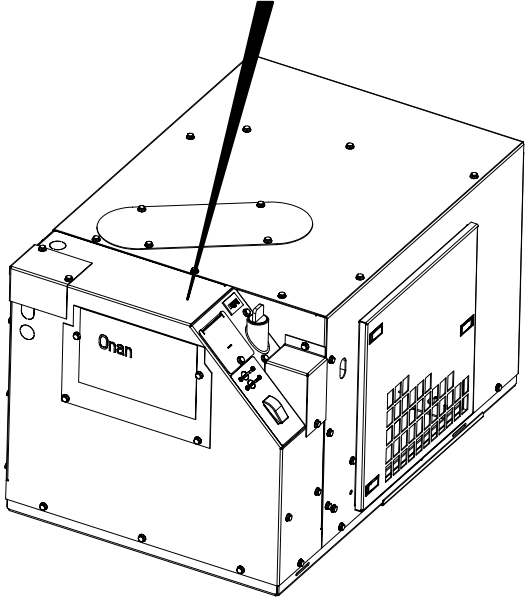

RECORD NUMBERS HERE

MODEL NUMBER:
SERIAL NUMBER:

**FIGURE 1. TYPICAL NAMEPLATE**

## FUEL RECOMMENDATIONS

**⚠️WARNING** Diesel fuel is combustible and can cause severe personal injury or death. Do not smoke near fuel tanks or fuel-burning equipment or in areas sharing ventilation with such equipment. Keep flames, sparks, pilot flames, electrical arcs and switches and all other sources of ignition well away. Keep a multi-class ABC fire extinguisher handy.

Use clean, fresh No. 2 diesel fuel (ASTM 2-D) when the outdoor ambient temperature is above freezing, and No. 1 diesel fuel (ASTM 1-D) when below freezing. The fuel should have a Cetane number of at least 45 for reliable starting.

## ENGINE OIL RECOMMENDATIONS

Use API (American Petroleum Institute) performance Class **CH-4** engine oil or better. Also look for the SAE (Society of Automotive Engineers) viscosity grade. Referring to Figure 2, choose the viscosity grade appropriate for the ambient temperatures expected until the next scheduled oil change. Multi-

grade oils such as SAE 15W-40 are recommended for year-round use.

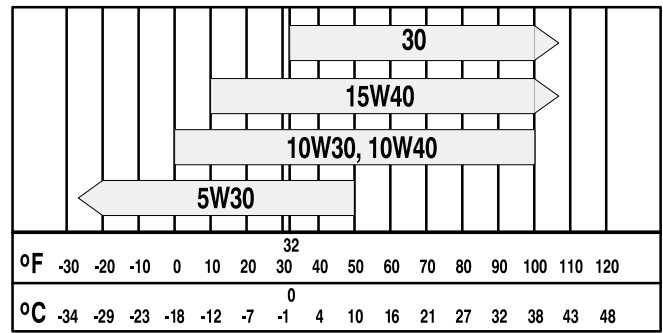

FIGURE 2. OIL VISCOSITY VS. TEMPERATURE

## STARTING BATTERIES

The genset requires a 12 volt battery to power its control and starting circuits. Reliable genset starting and starter service life depend upon adequate battery system capacity and maintenance. See *Specifications* (Page 29) for battery requirements and *Periodic Maintenance* (Page 17) for battery care.

## TYPICAL GENSET

Figure 3 illustrates a typical genset.

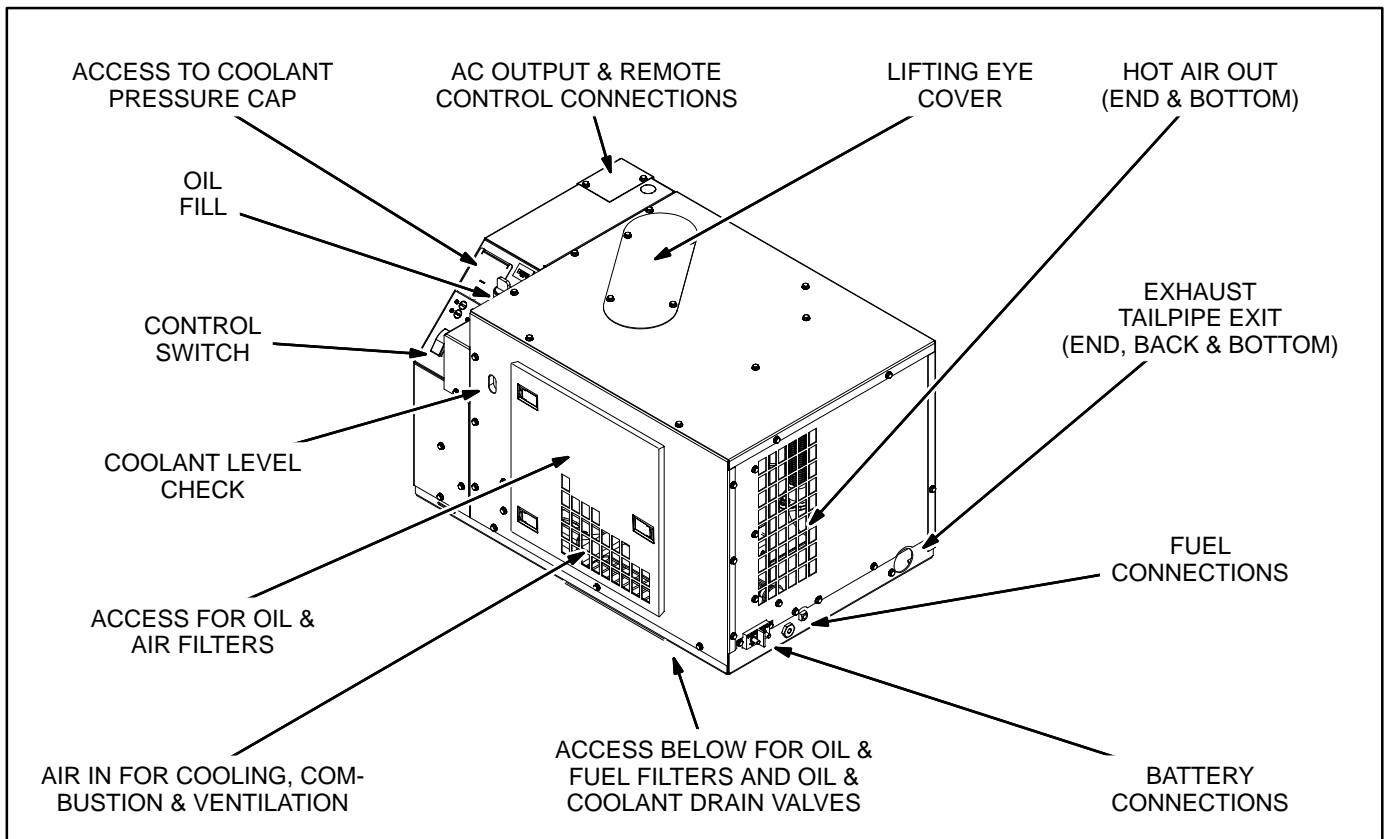

FIGURE 3. TYPICAL GENSET

## OPERATOR'S CONSOLE

The console (Figure 4) has the following features:

**Control Switch** - This switch is used to start and stop the genset, prime the engine fuel system and restore the fault code (blinking status light).

**Status Light** - This is an LED (light emitting diode) in the control switch which blinks rapidly during pre-heat and cranking. After the genset starts up, this light stays on continuously, indicating that the genset is running and that the starter has disconnected. If the genset shuts down, this light blinks in coded fashion to indicate the nature of the fault shutdown (see *Troubleshooting*, Page 22).

(Rapid blinking before cranking starts indicates that the glow plugs are preheating the combustion chambers. The controller automatically varies the time based on engine temperature.)

**Line Circuit Breakers** - The line circuit breakers protect the AC power leads connected to the genset.

**Coolant Pressure Cap** - The coolant pressure cap is under the access plate. Fill coolant here when refilling the system.

**Coolant Recovery Tank** - The recovery tank is mounted inside the genset and provides for coolant expansion. The coolant level is visible through the sight hole on the front of the genset. The fill cap is under the access cover. Replenish the normal loss of coolant here.

**Oil Fill Cap and Dipstick** - Check and fill engine oil.

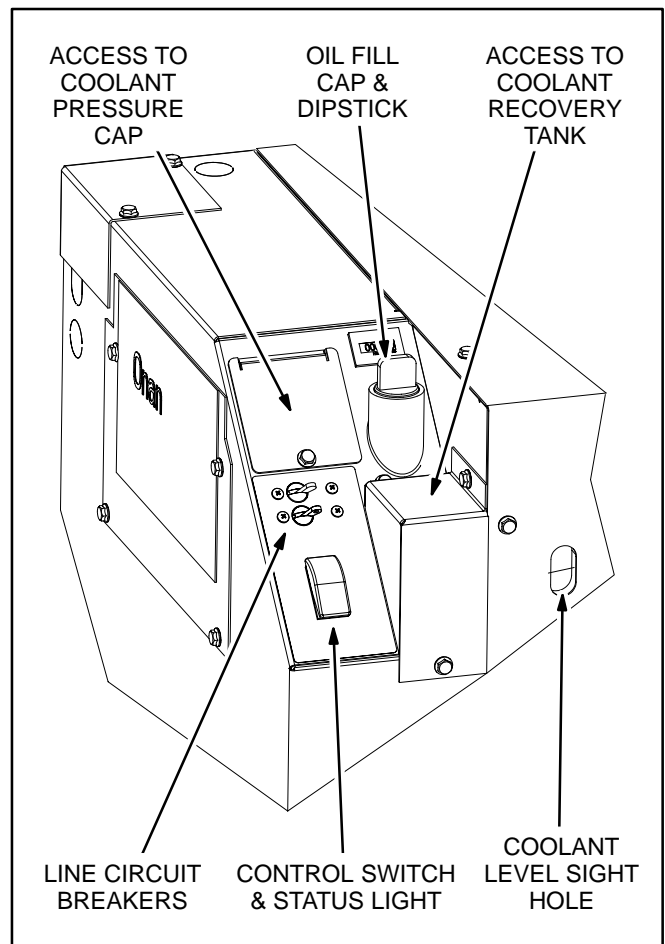

FIGURE 4. OPERATOR'S CONSOLE

## REMOTE CONTROL PANEL

The vehicle probably has a control panel inside the vehicle for remote control of the genset. Onan offers three remote control kits as follows:

- Remote switch / status lamp (Figure 5).
- Remote switch / status lamp and hour meter (Figure 6).
- Remote switch / status lamp and DC voltmeter (Figure 7).

The DC voltmeter indicates whether voltage across the 12 VDC control system and battery is normal. If the indicator consistently stays above or below the normal zone, see MAINTAINING THE BATTERY AND BATTERY CONNECTIONS (Page 17).

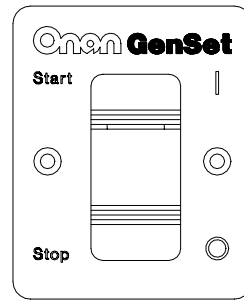

FIGURE 5. REMOTE SWITCH

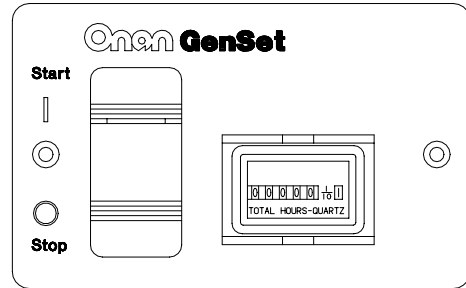

FIGURE 6. REMOTE SWITCH / HOUR METER

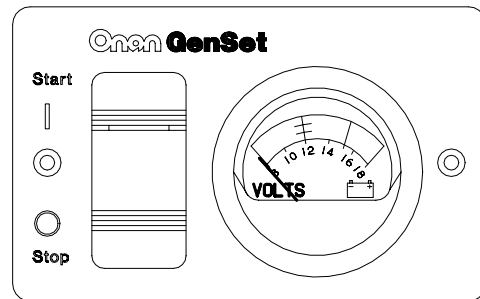

FIGURE 7. REMOTE SWITCH / DC VOLTMETER

# Operation

---

## **⚠️ WARNING** EXHAUST GAS IS DEADLY!

*All engine exhaust contains carbon monoxide; an odorless, colorless, poisonous gas that can cause unconsciousness and death. Symptoms of carbon monoxide poisoning include:*

- *Dizziness*
- *Headache*
- *Nausea*
- *Weakness and Sleepiness*
- *Vomiting*
- *Inability to Think Coherently*

**IF YOU EXPERIENCE ANY OF THESE SYMPTOMS, GET INTO FRESH AIR IMMEDIATELY. If symptoms persist, seek medical attention. Shut down the genset and do not operate it until it has been inspected and repaired.**

**Never sleep in the vehicle while the genset is running unless the vehicle has a working carbon monoxide detector. The exhaust system must be installed in accordance with the genset Installation Manual. Make sure there is ample fresh air when operating the genset in a confined area.**

## **CONDUCTING THE PRE-START CHECKS**

Before the first start of the day and after every eight hours of operation, inspect the genset as instructed under CONDUCTING GENERAL INSPECTIONS (Page 14). Keep a log of maintenance and the hours run and perform any maintenance that may be due. See Returning the Genset to Service (Page 12) if the vehicle has been in storage.

Before each start:

1. Make sure all vehicle CO detectors are working.
2. Check for signs of fuel and exhaust leaks and damage to the exhaust system.
3. To prevent overheating and to reduce fouling with dust and debris, make sure the genset's normal ground clearance is not being reduced by sloping ground, curbs, logs or other objects.

Repair the vehicle if necessary and/or remove any objects blocking the air inlet or air outlet.

4. Turn off air conditioners and other large equipment.

## **PRIMING THE FUEL SYSTEM**

The fuel system should be primed after replacing the fuel filter or running the genset out of fuel. To prime the fuel system hold the control switch down in its **Stop** position for at least 1 minute (starts in 2 seconds).

## **STARTING THE GENSET**

Start the genset from the genset control panel or remote control panel inside the vehicle.

1. Push and hold the switch at **START** until the genset starts. The status indicator light on the switch flashes during preheat and cranking. It will come on solid when the starter disconnects, indicating that the genset is running. (Depending on how cold it is, preheat can take up to 15 seconds, extending the time that the light blinks.)

**⚠️ CAUTION** *Excessive cranking can overheat and damage the starter motor. Do not crank for more than 30 seconds at a time. Wait at least 2 minutes before trying again.*

2. See *Troubleshooting* (Page 22) if the genset does not start after several tries.
3. For top performance and engine life, especially in colder weather, let the engine warm up for two minutes before connecting loads.
4. Check for fuel, exhaust and coolant leaks. Stop the genset immediately if there is a fuel, exhaust or coolant leak and have it repaired.

## **STOPPING THE GENSET**

Turn off air conditioners and other large loads and let the genset run for two minutes to cool down. Then push the switch to **STOP**.

## LOADING THE GENSET

The genset can power AC motors, air conditioners, AC/DC converters and other loads. How much load\* can be powered depends upon the genset power rating. The genset will shut down or its circuit breakers will trip if the sum of the loads exceeds genset power. See *Troubleshooting* (Page 22).

To avoid overloading the genset and causing shutdowns, compare the sum of the loads that are likely to be used at the same time to the power rating of the genset. ***It may be necessary to run fewer loads at the same time—the sum of the loads must not be greater than genset rating.***

Note that the genset may shut down due to overload when a large motor or air conditioner is started or cycles off and then on again, even though the sum of the loads is less than genset rating. The reason for this is that a motor's startup load is much larger than

its running load. ***It may be necessary to run fewer loads when large motors and air conditioners are cycling on and off.***

Note also that maximum power decreases as altitude increases because air density decreases. For every 1000-foot (305 m) increase in elevation you can expect power to decrease approximately 3 percent. Table 1 shows the results of typical calculations. ***It may be necessary to run fewer loads at higher altitudes.***

TABLE 1. POWER VS. ALTITUDE

Elevation above Sea Level	Maximum Power
at/below 500 ft (152 m)	5500 W (rated)
at 2500 ft (762 m)	5170 W
at 5500 ft (1676 m)	4675 W
above 5500 ft (1676 m)	4675 W minus 165 W every 1000 ft (305 m)

\* Equipment load and genset power are measured in terms of watts (W) or kilowatts (kW), where 1 kilowatt (kW) = 1000 watts (W).

## RESETTING CIRCUIT BREAKERS

If a circuit breaker in the main power distribution panel of the vehicle or on the genset (Figure 8) trips, either a circuit shorted or too many loads were running. Note that the genset will continue to run after a circuit breaker trips.

If a circuit breaker trips, disconnect or turn off as many loads as possible and reset the circuit breaker. (Push the circuit breaker to **OFF** to reset it and then to **ON** to reconnect the circuit.) If the circuit breaker trips right away, either the electrical distribution system has a short or the circuit breaker is faulty. Call a qualified electrician.

If the circuit breaker does not trip, reconnect the loads, one by one, up to a total load that does not overload the genset or cause the circuit breaker to trip. If a circuit breaker trips right away when an appliance is connected, the load equipment probably has a short.

Electrical equipment and tools must be used and maintained properly and be properly grounded to cause the line circuit breakers to trip when short circuits occur.

**⚠WARNING** *Short circuits in electrical equipment and tools can cause fire and electrical shock leading to severe personal injury or death. Read and follow the equipment and tool manufacturer's instructions and warnings regarding use, maintenance and proper grounding.*

## CONNECTING TO UTILITY POWER

A vehicle with provisions for connecting utility power must have an approved device to keep the genset and utility from being interconnected. See the genset Installation Manual for more information.

**⚠WARNING** *Interconnecting the genset and the public utility (or any other power source) can lead to electrocution of utility line workers, equipment damage and fire. Use an approved switching device to prevent interconnections.*

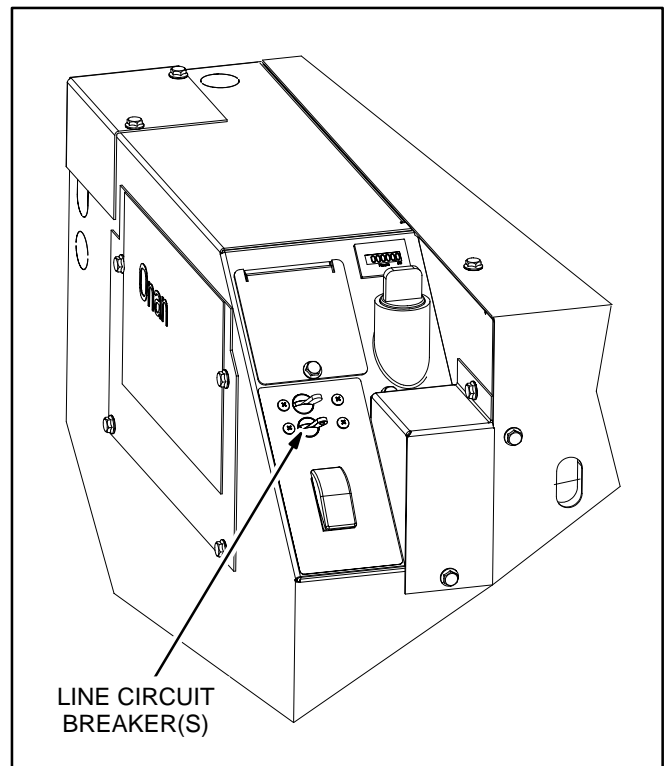

**FIGURE 8. LINE CIRCUIT BREAKERS**

## **OPERATING IN COLD WEATHER**

Make sure the engine oil viscosity is appropriate for the cold weather temperatures. See ENGINE OIL RECOMMENDATIONS (Page 5). Be sure to change the oil if a sudden drop in temperature occurs.

## **OPERATING IN HOT WEATHER**

Pay particular attention to the following items when operating the genset in hot weather:

1. Make sure nothing blocks airflow to and from the genset.
2. Make sure engine oil viscosity is appropriate for the ambient temperatures. See ENGINE OIL RECOMMENDATIONS (Page 5).
3. Keep the genset clean.
4. Perform maintenance due. See PERIODIC MAINTENANCE SCHEDULE (Page 13).

## **OPERATING AT HIGH ALTITUDE**

For the effect of altitude on maximum power, see LOADING THE GENSET (Page 9).

## **OPERATING IN DUSTY ENVIRONMENTS**

Pay particular attention to the following items when operating the genset in dusty environments:

1. Do not let dirt and debris accumulate inside the genset compartment. Keep the genset clean.
2. Perform air cleaner maintenance more often. See PERIODIC MAINTENANCE SCHEDULE (Page 13).

3. Change engine oil more often. See PERIODIC MAINTENANCE SCHEDULE (Page 13).
4. Keep containers of engine oil that have been opened tightly closed to keep out dust.

## **BREAKING IN A NEW ENGINE**

Proper engine break-in on a new genset or on one with a rebuilt engine is essential for top engine performance and acceptable oil consumption. Run the genset at approximately 1/2 rated power for the first 2 hours and then at 3/4 rated power for 2 more hours.

Proper engine oil and oil level are especially critical during break-in because of the higher engine temperatures that can be expected. Change the oil if not appropriate for the ambient temperatures during break-in. See ENGINE OIL RECOMMENDATIONS (Page 5). Check oil level twice a day or every 4 hours during the first 24 hours of operation and change the oil and oil filter after the first 50 hours of operation.

## **EXERCISING THE GENSET**

Exercise the genset at least 2 hours each month if use is infrequent. Run the genset at approximately 1/2 rated power. A single two hour exercise period is better than several shorter periods.

Exercising a genset drives off moisture, re-lubricates the engine, replaces stale fuel and removes oxides from electrical contacts. The result is better starting, more reliable operation and longer engine life.

## STORING THE GENSET

Proper storage is essential for preserving top genset performance and reliability when the genset cannot be exercised regularly and will be idle for more than 120 days.

### Storing the Genset

1. Push the genset line circuit breaker OFF (Page 10).
2. Change the engine oil and attach a tag indicating oil viscosity. See ENGINE OIL RECOMMENDATIONS (Page 5).
3. Disconnect the battery cables (negative [-] cable first) from the starting battery and store the battery according to the battery manufacturer's recommendations. See MAINTAINING THE BATTERY AND BATTERY CONNECTIONS (Page 17).
4. Plug the exhaust tail pipe to keep out dirt, moisture, bugs, etc.
5. Close the fuel supply valve (if so equipped).

## Returning the Genset to Service

1. Check the oil tag on the genset and change the oil if the viscosity indicated is not appropriate for the temperatures expected. See ENGINE OIL RECOMMENDATIONS (Page 5).
2. Reconnect the starting battery (negative [-] cable last). See MAINTAINING THE BATTERY AND BATTERY CONNECTIONS (Page 17).
3. Remove the plug from the exhaust tailpipe.
4. Change the air filter element if it is dirty (Page 17).
5. Open the fuel supply valve (if so equipped).
6. Inspect the genset. See CONDUCTING GENERAL INSPECTIONS (Page 14).
7. Push the genset line circuit breaker ON (Page 10) when the genset is ready to power appliances.

# Periodic Maintenance

Periodic maintenance is essential for top performance and long genset life. Use Table 2 as a guide for normal periodic maintenance. In hot and dusty environments some maintenance procedures should be performed more frequently, as indicated by the footnotes in the table. Keeping a log of maintenance performed and hours run (Page 32) will

help you keep genset maintenance regular and provide a basis for supporting warranty claims.

Maintenance, replacement or repair of emission control devices and systems may be performed by any engine repair establishment or individual. However, warranty work must be completed by an authorized Onan dealer.

**TABLE 2. PERIODIC MAINTENANCE SCHEDULE**

MAINTENANCE OPERATION	MAINTENANCE FREQUENCY						
	Every Day	After First 50 Hours	Every Month	Every 150 Hours	Every 500 Hours	Every 1000 Hours	Page
General Inspection	•						14
Check Engine Oil Level	•						15
Check Engine Coolant Level	•						21
Clean and Check Battery			• <sup>2</sup>				17
Clean Spark Arrestor				• <sup>3</sup>			18
Change Engine Oil and Oil Filter		•		• <sup>1, 2, 3</sup>			16
Replace Engine Air Filter					• <sup>1, 3</sup>		17
Replace Fuel Filter					• <sup>3</sup>		19
Check Coolant Anti-Freeze Protection					• <sup>3</sup>		14
Flush Coolant System						• <sup>4</sup>	14
Replace Coolant Pressure Cap						• <sup>4</sup>	14
Replace Engine V-belt (Coolant Pump)						• <sup>5, 6</sup>	-
Replace Coolant Hoses and Thermostat						• <sup>5, 6</sup>	-
Adjust Engine Valve Lash						• <sup>5, 6</sup>	-
Service Fuel Injectors						• <sup>5, 6</sup>	-
Check Generator Bearings, Drive Belt, Belt Tensioner & Drive Coupling						• <sup>5, 6</sup>	-
1 - Perform more often when operating in dusty conditions. 2 - Perform more often when operating in hot weather. 3 - Perform at least once a year. 4 - Perform at least once every two years. 5 - Perform at least once every five years. 6 - Must be performed by a qualified mechanic (authorized Onan dealer).							

## CONDUCTING GENERAL INSPECTIONS

Inspect the genset before the first start of the day and after every eight hours of operation.

### Oil Level

Check engine oil level (Page 15).

### Engine Coolant System

**⚠ CAUTION** *Operating the genset when coolant level is low can cause serious engine damage.*

Check the coolant level and look for coolant leaks around the bottom of the genset and on the ground below. Minor leaks that can be replenished by daily additions of coolant to the recovery tank should be repaired by a qualified service technician as soon as possible. Larger leaks are cause for shutting down the genset until it can be repaired.

### Exhaust System

**⚠ WARNING** *EXHAUST GAS IS DEADLY! Do not operate the genset if there is an exhaust leak or any danger of exhaust gases entering or being drawn into the vehicle.*

Look and listen for exhaust system leaks while the genset is running. Shut down the genset if a leak is found and have it repaired before operating the genset again.

Look for openings or holes between the genset compartment and vehicle cab or living space if the genset engine sounds louder than usual. Have all such openings or holes closed off or sealed to prevent exhaust gases from entering the vehicle.

Replace dented, bent or severely rusted sections of the tailpipe and make sure the tailpipe extends at least 1 inch (25.4 mm) beyond the perimeter of the vehicle.

Check all CO monitors to assure proper operation.

**⚠ WARNING** *Do not park the vehicle in high grass or brush. Contact with the exhaust system can cause a fire.*

Park the vehicle so that the genset exhaust gases can disperse away from the vehicle. Barriers such as walls, snow banks, high grass and brush and other vehicles can cause exhaust gases to accumulate in and around the vehicle.

Do not operate power ventilators or exhaust fans while the vehicle is standing with the genset running. The ventilator or fan can draw exhaust gases into the vehicle.

### Fuel System

Check for leaks at hose, tube and pipe fittings in the fuel supply system while the genset is running and while it is stopped. Check flexible fuel hose sections for cuts, cracks, and abrasions. Make sure the fuel line is not rubbing against other parts. Replace worn or damaged fuel line parts before leaks occur.

**⚠ WARNING** *Diesel fuel leaks can lead to fire. Do not operate the genset if operation causes fuel to leak.*

Prime the fuel system if the genset ran out of fuel.

### Battery Connections

Check the battery terminals for clean, tight connections. Loose or corroded connections have high electrical resistance which makes starting harder. See MAINTAINING THE BATTERY AND BATTERY CONNECTIONS (Page 17).

### Mechanical

Look for mechanical damage and listen for unusual noises. Check the genset mounting bolts.

To prevent overheating and to reduce fouling with dust and debris, make sure the genset's normal ground clearance is not being reduced by sloping ground, curbs, logs or other objects. Repark the vehicle if necessary and/or remove any objects blocking the air inlet or air outlet.

## CHECKING ENGINE OIL LEVEL

Park the vehicle on level ground and shut off the genset before checking engine oil level.

**⚠ WARNING** *Crankcase pressure can blow hot engine oil out the fill opening causing severe burns. Always stop the genset before removing the oil fill plug or drain.*

1. Pull the plug and dipstick out of the oil fill neck (Figure 9). The plug may be difficult to pull straight out. It is easier if you tilt the plug in its socket while pulling out. Wipe off the dipstick and thread it back into the fill neck and seat the plug, which snaps into its socket. Remove the plug and dipstick again and check the oil level on the dip stick.
2. Add or drain oil as necessary. See ENGINE OIL RECOMMENDATIONS (Page 5). Keep the oil level between the high and low beads on the end of the dipstick, as shown. It is not necessary to add oil between oil changes if the oil has not dropped more than 1/3 of the way between the high and low beads. Approximately 1 pint (0.4 liter) can be added if the oil level is at the lower bead.

**⚠ CAUTION** *Too much oil can cause high oil consumption. Too little oil can cause severe engine damage. Keep the oil level between the high and low beads on the dipstick.*

3. Secure the oil fill plug, which snaps into its socket.

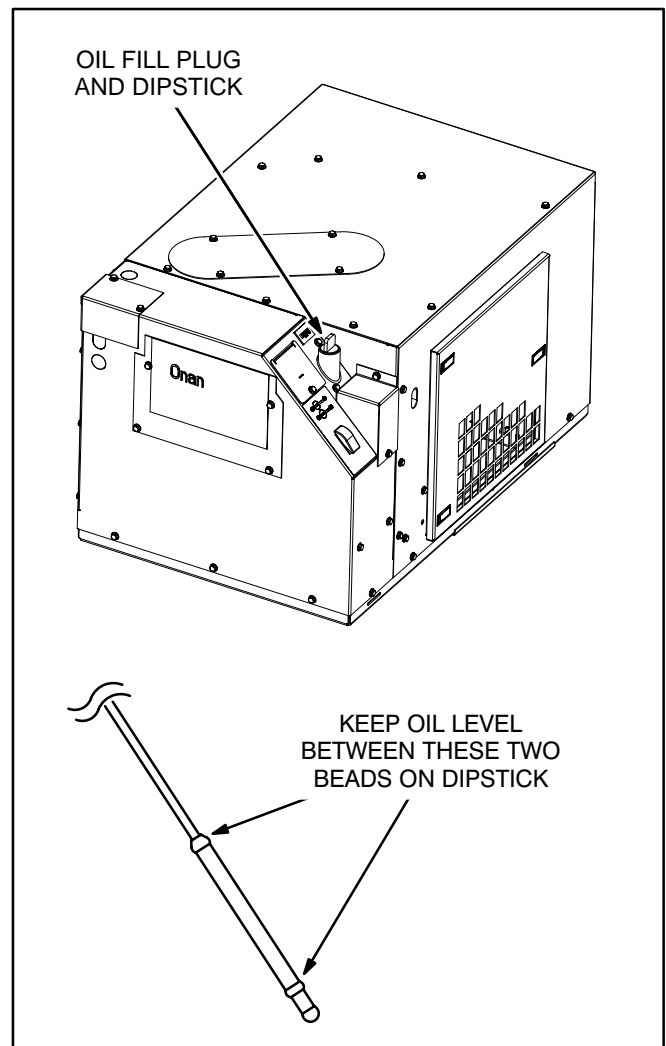

FIGURE 9. CHECKING ENGINE OIL LEVEL

## CHANGING ENGINE OIL AND OIL FILTER

Refer to Table 2 for scheduled engine oil change. Change oil more often in hot and dusty environments.

**⚠WARNING** *State and federal agencies have determined that contact with used engine oil can cause cancer or reproductive toxicity. Avoid skin contact and breathing of vapors. Use rubber gloves and wash exposed skin.*

**⚠WARNING** *To prevent accidental or remote starting while working on the genset, disconnect the negative (-) battery cable at the battery.*

1. Run the genset until warm and shut it off.
  2. Pull the oil dipstick (Page 15) out a couple of inches (50 mm) so that the oil will drain faster.
  3. Remove the front and bottom access covers (Figures 10 and 11) and direct the end of the drain hose into a container.
  4. Open the drain valve to drain all of the old oil.
  5. **Close the drain valve.**
  6. Spin off the oil filter and clean the filter mounting surface on the engine block. Remove the old gasket if it remains. (The oil filter is easier to remove through the front access opening.)
  7. Make sure the gasket is in place on the new filter and apply a thin film of clean oil to the gasket. Spin the new filter on until the gasket just touches the block. Turn it an additional 1/2 to 3/4 turn. Do not over tighten.
  8. Refill with 2 quarts (1.9 liters) of oil and check the level (Page 15).
  9. Secure the maintenance access covers for proper engine cooling and for protection from hazardous moving parts and hot exhaust manifolds.
- ⚠WARNING** *Do not run the genset with the maintenance access covers off. Contact with hazardous moving parts and hot exhaust manifolds can cause severe personal injury.*
10. Dispose of the used oil and oil filter according to local environmental regulations.

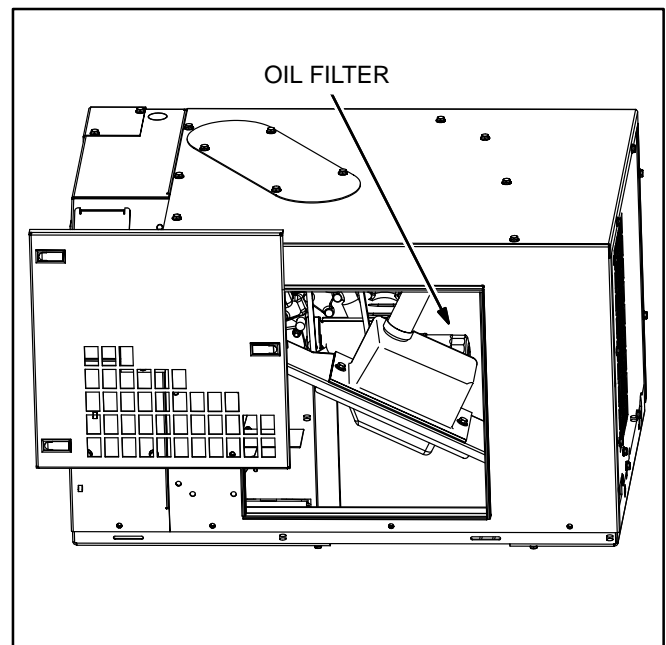

FIGURE 10. OIL FILTER ACCESS THROUGH FRONT

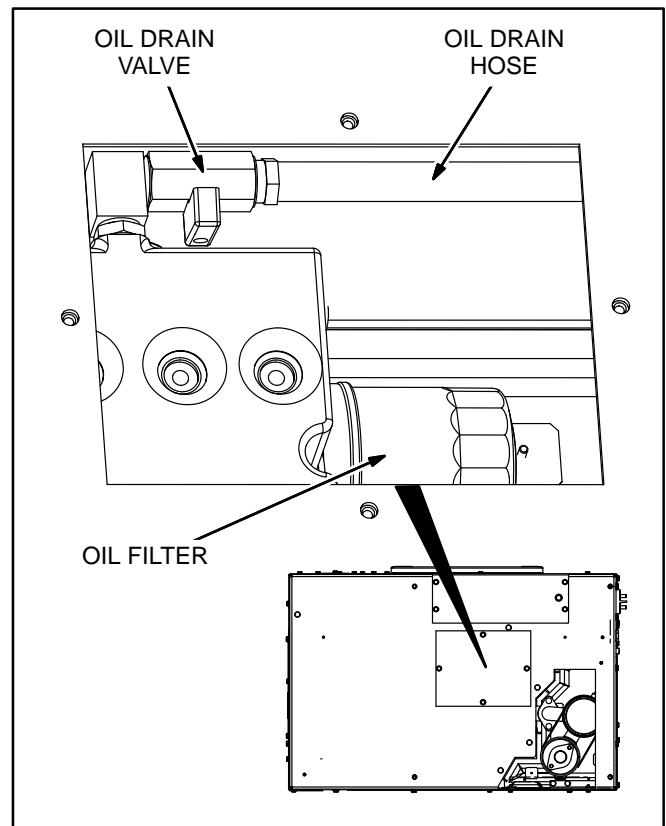

FIGURE 11. OIL DRAIN VALVE, DRAIN HOSE AND FILTER ACCESS THROUGH BOTTOM

## MAINTAINING THE BATTERY AND BATTERY CONNECTIONS

Refer to Table 2 for scheduled battery maintenance, and follow the battery manufacturer's instructions. Have the battery charging system serviced if DC system voltage is consistently low or high. Always:

**⚠WARNING** *Arcing at battery terminals or in light switches or other equipment, and flames or sparks, can ignite battery gas causing severe personal injury—Ventilate battery area before working on or near battery—Wear safety glasses—Do not smoke—Switch work light ON or OFF away from battery—Stop genset and disconnect charger before disconnecting battery cables—Disconnect negative (-) cable first and reconnect last.*

1. Keep the battery case and terminals clean and dry and the terminals tight.
2. Remove battery cables with a battery terminal puller.
3. Make sure which terminal is positive (+) and which is negative (-) before making battery connections, always removing the negative (-)

cable first and reconnecting it last to reduce arcing.

## REPLACING THE AIR FILTER ELEMENT

Refer to Table 2 for scheduled air filter element replacement. In dusty environments the filter element should be inspected and changed more frequently.

**⚠WARNING** *To prevent accidental or remote starting while working on the genset, disconnect the negative (-) battery cable at the battery.*

Remove the front access door, unscrew the 2 wing-nuts and pull away the filter housing and filter element (Figure 12).

When installing the new filter element, turn the wing-nuts hand tight.

Secure the maintenance access covers for proper engine cooling and for protection from hazardous moving parts and hot exhaust manifolds.

**⚠WARNING** *Do not run the genset with the maintenance access covers off. Contact with hazardous moving parts and hot exhaust manifolds can cause severe personal injury.*

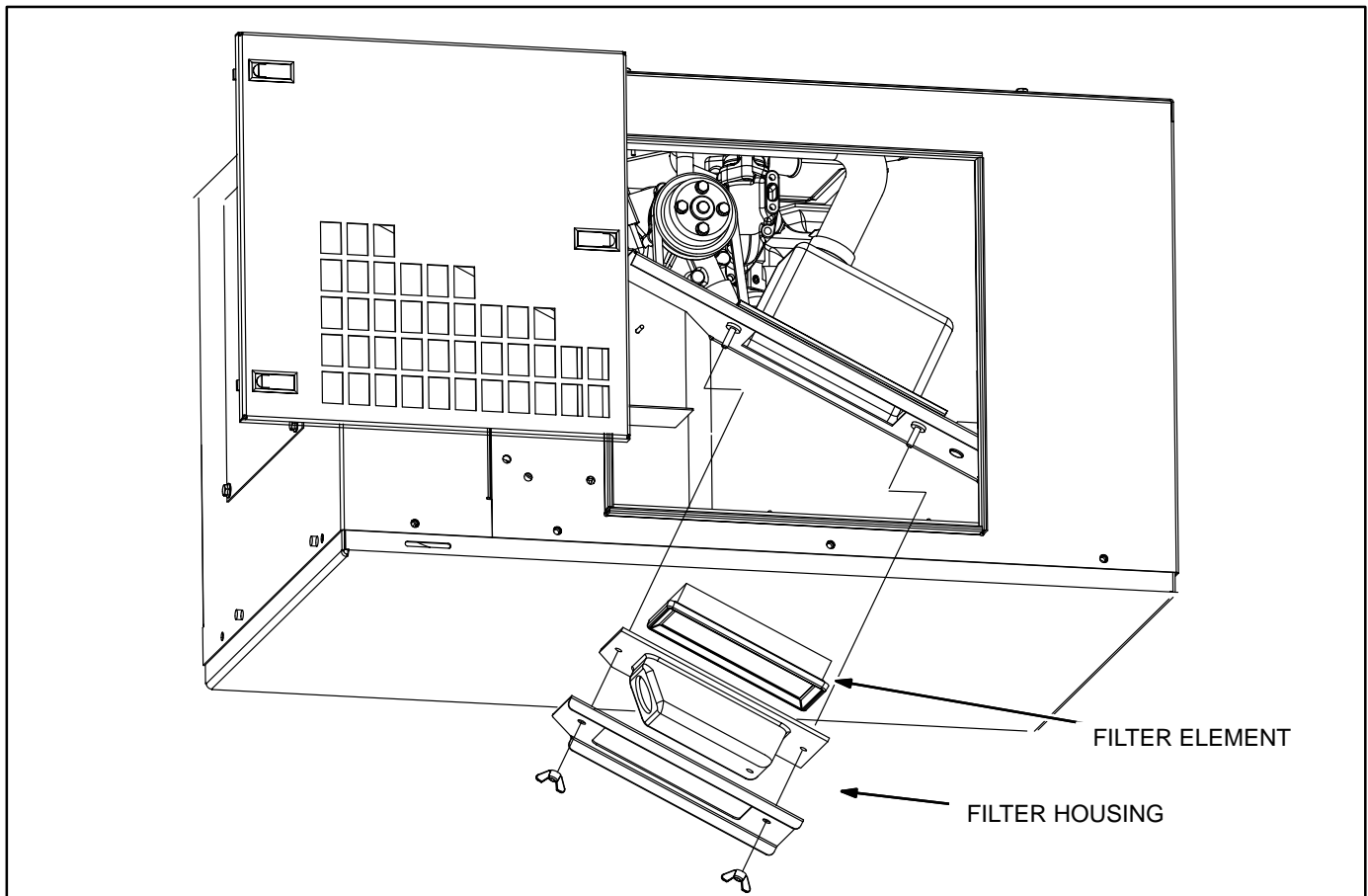

FIGURE 12. REMOVING THE AIR FILTER ASSEMBLY

## CLEANING THE SPARK ARRESTOR

Refer to Table 2 for scheduled cleaning of the spark arrestor muffler (which meets U.S. Forest Service requirements). Cleaning is required for maximum genset performance.

**⚠WARNING** *A hot muffler can cause severe burns. Let the muffler cool down before removing or installing the cleanout plug.*

The muffler is mounted inside the genset housing. The spark arrestor cleanout plug is located on the

side of the muffler and is accessible through the bottom (Figure 13). Clean out the muffler as follows:

1. Remove the cleanout plug (7/16 inch square head) from the muffler.
2. Start the genset and load it nearly to full power. Let the genset run for about five minutes to expel the soot.
3. Stop the genset, allow the muffler to cool down and reinstall the cleanout plug.

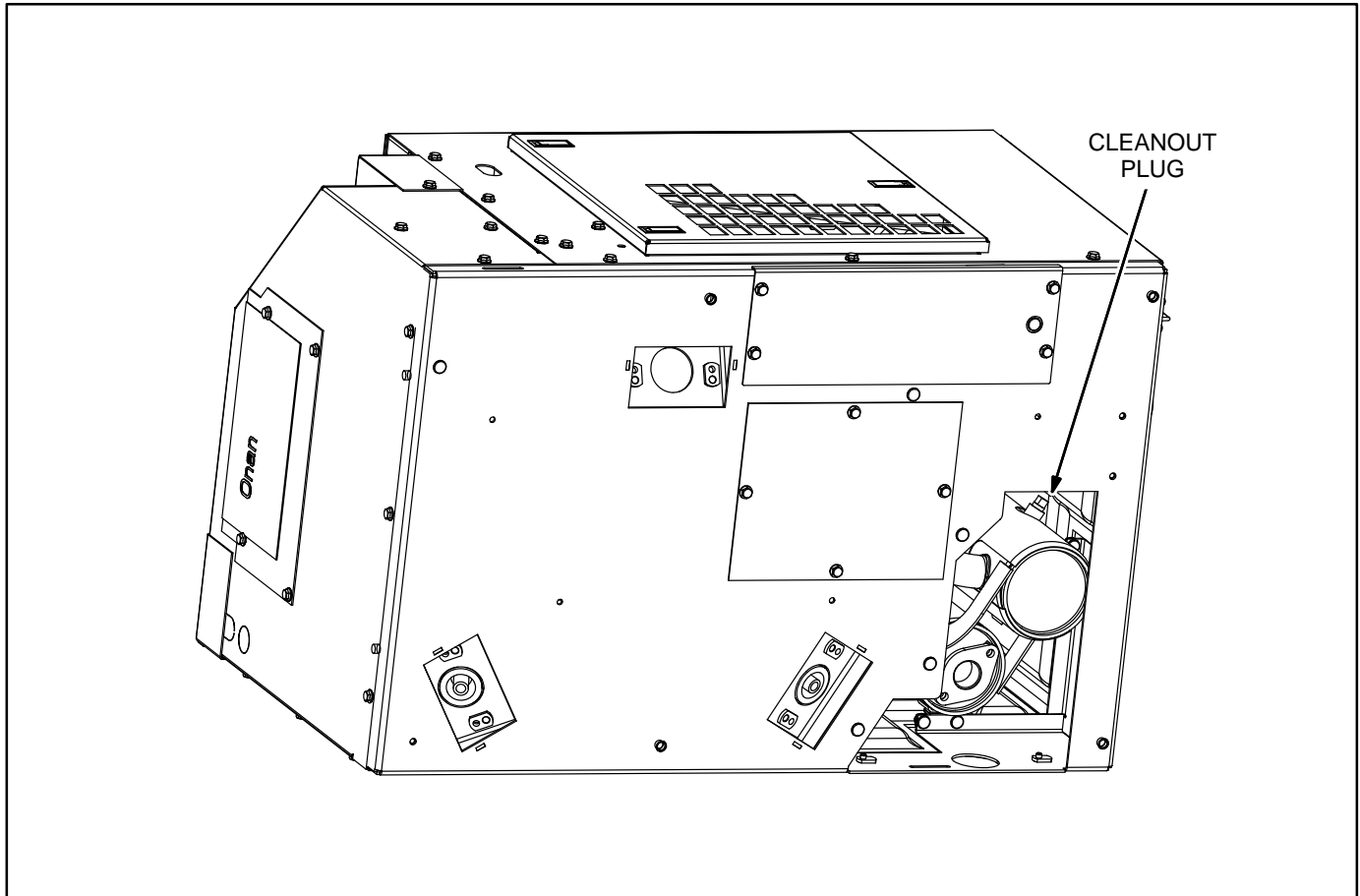

FIGURE 13. SPARK ARRESTOR CLEANOUT PLUG

## REPLACING THE FUEL FILTER

See Table 2 for scheduled fuel filter replacement. A dirty fuel filter may be the cause of a failure to start. The fuel filter is accessible through the bottom access opening (Figure 14).

**⚠WARNING** Diesel fuel is combustible and can cause severe personal injury or death. Do not smoke near diesel fuel tanks or equipment. Keep flames, sparks, pilot lights, electrical switches, arc-producing equipment and all other sources of ignition well away. Keep a type ABC fire extinguisher in the vehicle.

**⚠WARNING** To prevent accidental or remote starting while working on the genset, disconnect the negative (-) battery cable at the battery.

**Removing the Fuel Filter:** Take care to spill as little fuel as possible when disconnecting the filter from the fuel line. Close any shut off valve in the fuel line. Wipe dirt off the fuel hose fittings at the filter to keep dirt out of the fuel system.

To remove the filter, disconnect the two fittings at the filter. Use two flarenut wrenches on each fitting so

as not to round the corners or stress the fittings. Then remove the filter mounting nut and two (2) bracket mounting screws. Dispose of the fuel filter according to local regulations.

**Installing the Fuel Filter:** Secure the bracket loosely to the new filter. The filter and its bracket fit properly only one way.

Loosely secure the filter and bracket to the base with the two mounting screws and re-connect the fuel fittings. Take care not to cross thread the fuel fittings. Thread them in by hand and tighten one flat past seating. Finally, tighten the bracket and bracket mounting screws.

Prime the fuel system by holding the control switch down in its **Stop** position for at least 1 minute. Priming is necessary to fill the new filter with fuel.

Secure the maintenance access covers for proper engine cooling and for protection from hazardous moving parts and hot exhaust manifolds.

**⚠WARNING** Do not run the genset with the maintenance access covers off. Contact with hazardous moving parts and hot exhaust manifolds can cause severe personal injury.

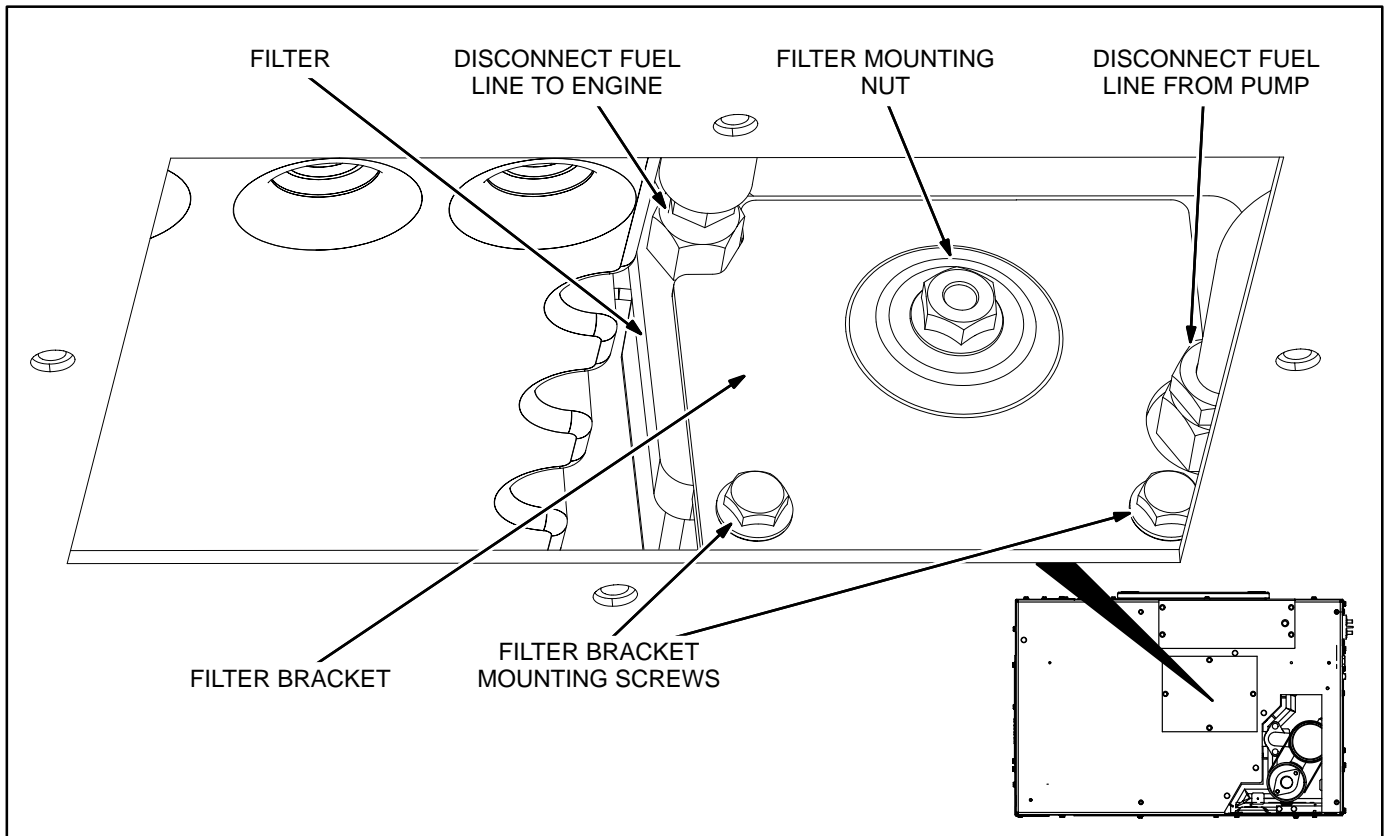

FIGURE 14. FUEL FILTER

## CHANGING COOLANT

Refer to Table 2 for scheduled maintenance. The engine cooling system is filled with a 50/50 mixture of ethylene glycol and water at the factory, which is suitable for temperatures down to  $-34^{\circ}\text{F}$  ( $-37^{\circ}\text{C}$ ).

### Recommended Coolant Mixture

Use the best quality ethylene glycol antifreeze solution available. It should be fully formulated with rust inhibitors and coolant stabilizers. Use fresh water that is low in minerals and corrosive chemicals. Distilled water is best.

**⚠WARNING** *Hot coolant spray can cause severe burns. Let the engine cool before releasing the pressure cap or opening the drain cock.*

### Replacing the Pressure Cap

Replace the pressure cap (Figure 16) every two years (seals deteriorate and leak). Proper cooling system pressure (14 psi) is essential for optimal engine cooling and minimal coolant loss.

### Draining the Cooling System

**⚠WARNING** *To prevent accidental or remote starting while working on the genset, disconnect the negative (-) battery cable at the battery.*

Let the engine cool before removing the pressure cap. Relieve any remaining pressure by turning the pressure cap slowly, without pushing down. To remove the cap, push down and turn it the rest of the way. Then remove the bottom access cover (Figure 15), open the radiator drain cock and drain the coolant into a suitable container. Approximately 1.6 quarts (1.5 L) will drain.

**⚠WARNING** *Ethylene glycol antifreeze is considered toxic. Dispose of it according to local regulations for hazardous substances.*

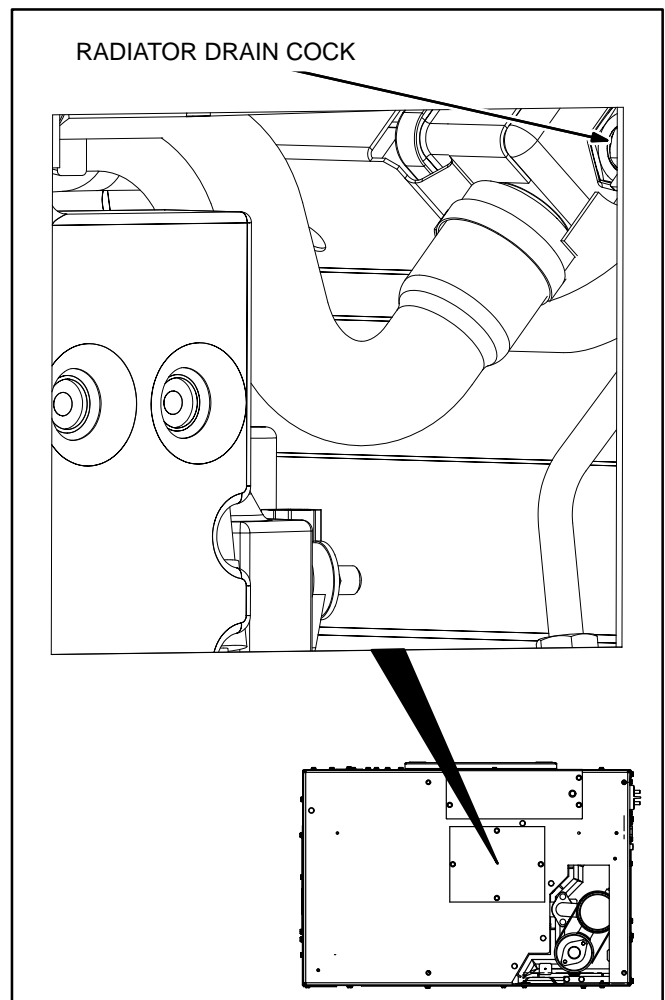

FIGURE 15. LOWER RADIATOR HOSE

## Cleaning the Cooling System

Clean and flush the cooling system with radiator cleaning chemicals available at auto parts stores. Follow the instructions for cleaning and flushing that come with the cleaning solution.

## Refilling the Cooling System

Close the radiator drain cock and fill the system with coolant through the fill opening. Pull the hose connected to the pressure cap assembly out as far as it will go. When the coolant level reaches the fill opening, start and operate the genset for a few minutes and shut it down. Add more coolant if necessary and secure the pressure cap.

Secure the maintenance access covers for proper engine cooling and for protection from hazardous moving parts and hot exhaust manifolds.

**⚠️WARNING** *Do not run the genset with the maintenance access covers off. Contact with hazardous moving parts and hot exhaust manifolds can cause severe personal injury.*

Fill the recovery tank with coolant mixture to the COLD mark.

## Checking Coolant Level

Check coolant level in the recovery tank (Figure 16) before the first startup of each day and fill to the COLD mark if necessary.

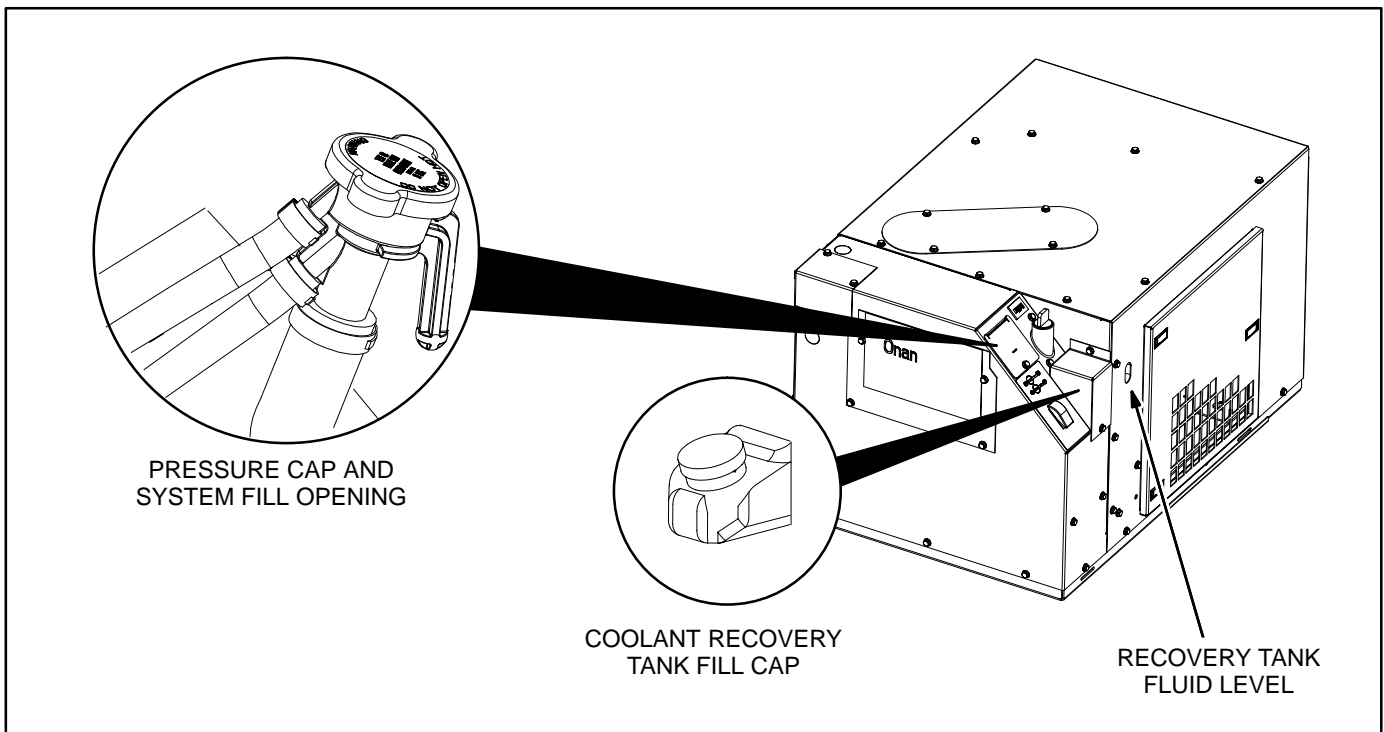

**FIGURE 16. ENGINE COOLING SYSTEM PRESSURE CAP AND RECOVERY TANK**

# Troubleshooting

---

TABLE 3. TROUBLESHOOTING lists the shutdown codes in numerical order along with step-by-step corrective actions. If you are unable to resolve the problem after taking the corrective actions suggested, contact an authorized Onan dealer. See *How to Obtain Service* (Page 31).

First note the following:

- Maintaining engine oil and coolant levels, keeping battery connections clean and tight, watching the fuel gauge, not overloading the genset, keeping the air inlet and outlet openings clear, etc. will prevent most shutdowns.
- When the genset and vehicle engine share a common fuel tank the fuel dip tubes are usually arranged so that the genset will run out of fuel first. Marking the genset empty point on the fuel gauge will make it easier to tell when to stop the genset before running it out of fuel.

## SHUTDOWN CODES

The genset controller provides extensive diagnostics by causing the status indicator light on the Control Switch to blink in a coded fashion. Following a fault shutdown, the indicator light will repeatedly blink 1, 2, 3 or 4 blinks at a time.

- **One blink** indicates shut down due to high temperature.

- **Two blinks** indicate shutdown due to a loss of engine oil pressure.
- **Three blinks** indicate a service fault. Press **Stop** once to cause the two-digit, second-level shutdown code to blink. (Pressing **Stop** again will stop the blinking.) The two-digit code consists of 1, 2, 3, 4 or 5 blinks, a brief pause, and then 1 to 9 blinks. The first set of blinks represents the tens digit and the second set of blinks the units digit of the shutdown code number. For example, **shutdown code No. 36** appears as:

blink-blink-blink—*pause*—blink-blink-blink-blink-blink-blink—  
*long pause*—repeat

- **Four blinks** indicate that cranking exceeded a preset time (20 seconds if ambient temperature is above 32° F[0° C], 30 seconds if below) without starting.
- **Note: shutdown code Nos. 3 and 4 are first level faults. Avoid interpreting them as second-level shutdown code Nos. 33 and 44, which have not been assigned as shutdown codes.**

**Restoring Shutdown Code Blinking** - The shutdown code stops blinking after five minutes. Press **Stop** three times within three seconds to restore blinking. **Note that the last fault logged will blink, even after the condition that caused the shutdown has been corrected.**

TABLE 3. TROUBLESHOOTING

**⚠ WARNING** *Some genset service procedures present hazards that can result in severe personal injury or death. Only trained and experienced service personnel with knowledge of fuels, electricity, and machinery hazards should perform genset service. See Safety Precautions.*

**NO RESPONSE—DEAD STATUS INDICATOR LIGHT**

(Poor connections, faulty wiring or dead battery)

**Corrective Action:**

1. Try starting the genset at the operator's console if it does not start at the remote panel.
2. Clean and tighten the battery cable connections at the battery and at the genset.
3. Recharge or replace the battery. Refer to the battery manufacturer's recommendations.

**THE STARTING BATTERIES DO NOT MAINTAIN A CHARGE**

(The battery, battery connections or charging system are in marginal condition)

**Corrective Action:**

1. Clean and tighten the battery cable connections at the battery and at the genset.
2. Recharge or replace the battery. Refer to the battery manufacturer's recommendations.

**THE STARTER ENGAGES AND DISENGAGES**

(Cranking voltage dips below 6 volts because of low battery charge or poor connections)

**Corrective Action:**

1. Have the vehicle propulsion engine running while trying to start the genset. (The battery charging alternator may be able to maintain starting voltage high enough to get the genset started.)
2. Clean and tighten the battery cable connections at the battery and at the genset.
3. Recharge or replace the battery. Refer to the battery manufacturer's recommendations.

**THERE IS NO POWER WHEN THE GENSET IS RUNNING**

(A line circuit breaker is OFF, tripped or malfunctioning)

**Corrective Action:**

1. Reset or turn ON the line circuit breaker on the genset (Page 10).
2. Reset or turn ON any other circuit breaker in the power supply system.

**THE GENSET WILL NOT STOP RUNNING (THE RUN LIGHT IS OFF)**

(The governor mechanism is stuck or binding)

**Corrective Action:** Close the fuel supply valve, if provided, or squeeze off the fuel supply line and see an authorized Onan dealer.

TABLE 3. TROUBLESHOOTING (CONT.)

**⚠ WARNING** *Some genset service procedures present hazards that can result in severe personal injury or death. Only trained and experienced service personnel with knowledge of fuels, electricity, and machinery hazards should perform genset service. See Safety Precautions.*

**HIGH TEMPERATURE FAULT—CODE NO. 1**

(First-level fault code—engine coolant temperature exceeded 230° F [110° C])

**Corrective Action:**

1. Check the engine coolant level and add coolant as necessary (Page 21).
2. Check for and remove any objects blocking the air inlet or outlet openings in the bottom and sides of the genset.
3. Flush the coolant system to remove coolant passage fouling (Page 20).

**LOW OIL PRESSURE FAULT—CODE NO. 2**

(First-level fault code—the low oil pressure cutoff switch is open)

**Corrective Action:**

1. Check the engine oil level and add oil as necessary (Page 15).
2. Drain the excess oil if the oil level is above the Full mark on the dipstick. (The oil will foam if the level is too high and result in possible loss of oil pressure.)

**SERVICE CHECK—CODE NO. 3**

(First-level fault code—a second-level fault occurred)

**Corrective Action:** Check the second-level fault code by momentarily pressing Stop. The second-level fault will be one of the following in this table.

**OVERCRANK FAULT—CODE NO. 4**

(First-level fault code—Cranking without starting exceeded 20 to 30 seconds, depending on ambient)

**Corrective Action:**

1. Check the fuel level and refill as necessary. (Note: The genset fuel pickup is probably higher than the vehicle engine fuel pickup.)
2. Check for fuel (air) leaks at all fuel fittings and tighten as necessary. Prime the engine fuel system by holding the control switch at **Stop** for one minute.
3. Check the engine air filter (Page 17) and remove any blockage.
4. Check for mechanical damage.
5. Replace the fuel filter (Page 19).

**OVERVOLTAGE FAULT—CODE NO. 12**

(The controller is not able to regulate to rated voltage)

**Corrective Action:** See an authorized Onan dealer.

TABLE 3. TROUBLESHOOTING (CONT.)

**⚠ WARNING** *Some genset service procedures present hazards that can result in severe personal injury or death. Only trained and experienced service personnel with knowledge of fuels, electricity, and machinery hazards should perform genset service. See Safety Precautions.*

**UNDERVOLTAGE FAULT—CODE NO. 13**

(The controller is not able to regulate to rated voltage)

**Corrective Action:** Turn OFF the line circuit breaker on the operator's console. If the genset now runs, run it with fewer connected loads.

**OVERFREQUENCY FAULT—CODE NO. 14**

(The controller is not able to regulate to rated frequency)

**Corrective Action:**

1. Check for a tripped genset circuit breaker, reset it if necessary, and run with fewer connected loads. (A breaker tripping under load can cause frequency to overshoot.)
2. Check for fuel (air) leaks at all fuel fittings and tighten as necessary. Prime the engine fuel system by holding the control switch at **Stop** for one minute. (Air bubbles can disrupt frequency.)

**UNDERFREQUENCY FAULT—CODE NO. 15**

(The controller is not able to regulate to rated frequency)

**Corrective Action:**

1. Turn OFF the line circuit breaker. If the genset now runs, run it with fewer connected loads, especially those with high motor starting loads such as air conditioners.
2. Check the fuel level and refill as necessary. (Note: The genset fuel pickup is probably higher than the vehicle engine fuel pickup.)
3. Check for fuel (air) leaks at all fuel fittings and tighten as necessary. Prime the engine fuel system by holding the control switch at **Stop** for one minute. (Air bubbles can disrupt frequency.)
4. Check the engine air filter (Page 17) and remove any blockage.
5. Check for mechanical damage.
6. Replace the fuel filter (Page 19).

**GOVERNOR ACTUATOR FAULT—CODE NO. 19**

(The controller sensed that the actuator circuit is either open or shorted)

**Corrective Action:** See an authorized Onan dealer.

TABLE 3. TROUBLESHOOTING (CONT.)

**⚠ WARNING** *Some genset service procedures present hazards that can result in severe personal injury or death. Only trained and experienced service personnel with knowledge of fuels, electricity, and machinery hazards should perform genset service. See Safety Precautions.*

**GOVERNOR OVERLOAD FAULT—CODE NO. 22**

(The duration of operation at or near full-duty cycle was beyond the design limit)

**Corrective Action:**

1. Reduce the number of appliances running at the same time, especially those with high motor starting loads such as air conditioners.
2. Check for fuel (air) leaks at all fuel fittings and tighten as necessary. Prime the engine fuel system by holding the control switch at **Stop** for one minute.
3. Replace the engine air filter (Page 17) and clean the spark-arrest muffler (Page 18).
4. Replace the fuel filter (Page 19).

**TEMPERATURE SENDER FAULT—CODE NO. 24**

(The controller sensed that the sender circuit is either open or shorted)

**Corrective Action:** See an authorized Onan dealer.

**AC VOLTAGE SENSE FAULT—CODE NO. 27**

(The controller was unable to sense output voltage)

**Corrective Action:** See an authorized Onan dealer.

**HIGH BATTERY VOLTAGE FAULT—CODE NO. 29**

(The controller sensed battery system voltage greater than 19 volts)

**Corrective Action:**

1. Check battery bank connections and reconnect, if necessary, so that the 12 volt batteries serving the genset are connected in parallel (12 volt) rather than in series (24 volt).
2. Select a lower battery booster charge rate.

**LOW CRANKING SPEED FAULT—CODE NO. 32**

(Cranking speed less than 100 rpm [2.5 Hz, generator] for more than 12 seconds)

**Corrective Action:**

1. Have the vehicle propulsion engine running while trying to start the genset. (The battery charging alternator may be able to maintain starting voltage high enough to get the genset started.)
2. Clean and tighten the battery cable connections at the battery and at the genset.
3. Recharge or replace the battery. Refer to the battery manufacturer's recommendations.
4. Replace engine oil with oil of proper viscosity for ambient temperatures. (High oil viscosity can slow down cranking speed.)

TABLE 3. TROUBLESHOOTING (CONT.)

**⚠ WARNING** *Some genset service procedures present hazards that can result in severe personal injury or death. Only trained and experienced service personnel with knowledge of fuels, electricity, and machinery hazards should perform genset service. See Safety Precautions.*

**CONTROL CARD FAULT—CODE NO. 35**  
(Microprocessor EEPROM error during self-test)

**Corrective Action:** See an authorized Onan dealer.

**ENGINE STOPPED FAULT—CODE NO. 36**  
(The genset stopped without a command from the controller)

**Corrective Action:**

1. Check the fuel level and refill as necessary. (Note: The genset fuel pickup is probably higher than the vehicle engine fuel pickup.)
2. Check for fuel (air) leaks at all fuel fittings and tighten as necessary. Prime the engine fuel system by holding the control switch at **Stop** for one minute.
3. Check the engine air filter (Page 17) and remove any blockage.
4. Check for mechanical damage.
5. Replace the fuel filter (Page 19).

**FIELD OVERLOAD FAULT—CODE NO. 38**  
(Field voltage exceeded 150 VDC)

**Corrective Action:**

1. Reduce the number of air conditioners running at the same time (and other appliances that cause low power factor).
2. Have the air conditioners and other appliances checked for proper operation. (A locked compressor rotor can cause very low power factor.)

**SHORTED ROTOR FAULT—CODE NO. 41**  
(The rotor circuit is shorted to ground)

**Corrective Action:** See an authorized Onan dealer.

**PROCESSOR FAULT—CODE NO. 42**  
(Microprocessor ROM error during self-test)

**Corrective Action:** See an authorized Onan dealer.

**PROCESSOR FAULT—CODE NO. 43**  
(Microprocessor RAM error during self-test)

**Corrective Action:** See an authorized Onan dealer.

TABLE 3. TROUBLESHOOTING (CONT.)

**⚠ WARNING** *Some genset service procedures present hazards that can result in severe personal injury or death. Only trained and experienced service personnel with knowledge of fuels, electricity, and machinery hazards should perform genset service. See Safety Precautions.*

**SPEED SENSE FAULT—CODE NO. 45**  
(Controller unable to sense quadrature frequency)

**Corrective Action:** Check the fuel level and fill as necessary. Then prime the engine fuel system by holding the control switch at **Stop** for one minute and try restarting.

**OVERPRIME FAULT—CODE NO. 57**  
(Prime mode exceeded 3 minutes)

**Corrective Action:** Check for and remove any object that may be holding either control switch (remote or local) in the prime (stop) position.

# Specifications

	60 Hz Models	50 Hz Models
<b>GENSET CONTROLLER:</b> Integrated Microprocessor Based Engine and Generator Controller		
<b>GENERATOR:</b> Two-Bearing, Two-Pole Rotating Field, "Poly-Vee" Belt Drive		
Power (@1.0 PF)	5500 W	5000 W
RPM	3600	3000
Voltage	120V 1-Ph, 120/240V 1-Ph, or 120/240V 3-Ph	115/230V 1-Ph or 230/400V 3-Ph
Current	45.8A, 22.9A, or 13.2A	23.9A or 7.2A
Circuit Breakers	25A, 25A, or 15A	25A or 8A
<b>FUEL CONSUMPTION:</b>		
No-load	0.25 gph (0.93 lph)	0.21 gph (0.78 lph)
Half-load	0.41 gph (1.57 lph)	0.34 gph (1.31 lph)
Full-load	0.66 gph (2.51 lph)	0.55 gph (2.09 lph)
<b>ENGINE:</b> 2-Cylinder In-Line, Water-Cooled, Indirect-Injection, 4-Stroke Cycle Diesel		
RPM	2880	2400
Bore	2.64 in (67 mm)	
Stroke	2.68 in (68 mm)	
Displacement	29.23 in <sup>3</sup> (479 cc)	
Compression Ratio	23 : 1	
Fuel Injection Timing (BTDC)	18° - 20°	
Injection Order	1-2	
Fuel Nozzle Injection Pressure	1991 psi (13.73 mPa)	
Valve Lash: Intake & Exhaust (cold)	0.0059 - 0.0073 inch (0.145 - 0.185 mm)	
Oil Capacity (with filter)	2 quart (1.9 liter)	
Cooling System Capacity	2.5 quart (2.4 liter)	
<b>DC SYSTEM:</b>		
Nominal Battery Voltage	12 volts	
Minimum Battery Capacity CCA (Cold Cranking Amps)	475 amps down to 0° F (-17° C) 650 amps down to -20° F (-29° C)	
Fuse F1 (control, start and glow plug circuits)	30 amp mini-bayonet	
<b>WEIGHT:</b> 400 lbs (181 kg)		
<b>SIZE (L x W x H):</b> 34.5 x 22.4 x 20.3 in (846 x 549 x 498 mm)		
<b>SOUND LEVEL:</b> 68 dB(A) @ 10 ft (3m)		

# Emissions

The engine has a label on the side of the valve cover, facing the maintenance side of the genset, which states compliance with applicable EPA and California emissions regulations.

California users of these gensets should be aware that unauthorized modifications or replacement of fuel, exhaust, air intake, or speed control system components that affect engine emissions are prohibited. Unauthorized modification, removal or replacement of the genset label is prohibited.

You should carefully review Operator (Owner), Installation and other manuals and information you receive with your genset. If you are unsure that the installation, use, maintenance or service of your genset is authorized, you should seek assistance from an approved Onan dealer.

California genset users may use Table 4 as an aid in locating information related to the California Air Resources Board requirements for emissions control.

**TABLE 4. EMISSIONS CONTROL INFORMATION**

Emissions Warranty Information	The California emissions control warranty statement is located in the same packet of information as this manual when the engine is shipped from the factory.
Engine Valve Clearance (Lash)	See <i>Specifications</i> (Page 29).
Engine Fuel Requirements	The engine is certified to operate on diesel fuel. See FUEL RECOMMENDATIONS (Page 5).
Engine Lubricating Oil Requirements	See ENGINE OIL RECOMMENDATIONS (Page 5).
Engine Adjustments	High Idle Speed. This is a service procedure requiring trained personnel and proper tools. See the Service Manual.
Engine Emission Control System	The engine emission control system consists of engine design and precision manufacture. <b>(IFI)</b>

# How to Obtain Service

---

When you need service, parts, or product literature (such as the Service Manual) for your genset, contact the nearest authorized distributor. Onan has factory-trained representatives to handle your needs for genset parts and service.

Call 1-800-888-ONAN to contact the nearest Cummins/Onan or Onan-only distributor in the United States or Canada. (This automated service utilizes touch-tone phones only). Select OPTION 1 (press 1) to be automatically connected to the distributor nearest to you.

If you are unable to contact a distributor using the automated service, consult the Yellow Pages. Typically, our distributors are listed under:

GENERATORS - ELECTRIC,  
ENGINES - GASOLINE OR DIESEL, or  
RECREATIONAL VEHICLES - EQUIPMENT,  
PARTS AND SERVICE.

If you are outside North America, call Onan Corporation at 1-763-574-5000 from 7:30 AM to

4:00 PM, Central Standard Time, Monday through Friday, or fax 1-763-528-7229.

Before calling for service, have the following information available:

1. *The complete genset model number and serial number. See Model Identification (Page 4).*
2. *The date of purchase*
3. *The nature of the problem. See Troubleshooting (Page 22).*

If you have difficulty in arranging service or resolving a problem, please contact the Service Manager at the nearest Cummins/Onan distributor for assistance.

**⚠WARNING** *Improper service or replacement of parts can result in severe personal injury, death, and/or equipment damage. Service personnel must be trained and experienced in performing electrical and/or mechanical service.*





Cummins Power Generation  
1400 73rd Avenue N.E.  
Minneapolis, MN 55432  
763-574-5000  
Fax: 763-528-7229

Cummins and Onan are registered trademarks of Cummins Inc.