

# **Operator's Manual**

**MDKBH**

**California**

**Proposition 65 Warning**

**Diesel engine exhaust and some of its constituents are known to the State of California to cause cancer, birth defects, and other reproductive harm.**

# Table of Contents

---

SECTION	PAGE
SAFETY PRECAUTIONS .....	iii
1. INTRODUCTION .....	1-1
About this Manual .....	1-1
Model Identification .....	1-1
How to Obtain Service .....	1-2
Emissions Label .....	1-2
2. CONTROL PANELS .....	2-1
Local Control Panel .....	2-1
Remote Control and Monitoring .....	2-1
Digital Display .....	2-2
3. OPERATION .....	3-1
Fuel .....	3-1
Engine Oil .....	3-1
Engine Coolant .....	3-2
Batteries .....	3-2
Fire Extinguisher Port .....	3-2
Pre-Start Checks .....	3-3
Priming the Fuel System .....	3-3
Starting the Genset .....	3-3
Stopping the Genset .....	3-4
Emergency Stop .....	3-4
Loading the Genset .....	3-4
No-Load Operation .....	3-5
Resetting Line Circuit Breakers .....	3-5
Connecting to Shore Power .....	3-5
Cold Temperature Operation .....	3-5
Care of New or Re-Built Engine .....	3-5
Exercising the Genset .....	3-5
Storing the Genset .....	3-6

<b>SECTION</b>	<b>PAGE</b>
4. PERIODIC MAINTENANCE .....	4-1
General Inspection .....	4-2
Maintaining the Battery and Battery Connections .....	4-2
Checking Engine Oil Level .....	4-3
Changing Engine Oil and Filter .....	4-4
Draining/Replacing the Fuel Filter .....	4-5
Maintaining the Engine Cooling System .....	4-6
5. TROUBLESHOOTING .....	5-1
Troubleshooting with Digital Display .....	5-1
Troubleshooting with Status Lamp .....	5-1
6. SPECIFICATIONS .....	6-1
7. MAINTENANCE RECORD .....	7-1

# SAFETY PRECAUTIONS

---

Thoroughly read the **OPERATOR'S MANUAL** before operating the genset. Safe operation and top performance can only be obtained when equipment is operated and maintained properly.

The following symbols in this manual alert you to potential hazards to the operator, service person and equipment.

**⚠ DANGER** alerts you to an immediate hazard that will result in severe personal injury or death.

**⚠ WARNING** alerts you to a hazard or unsafe practice that can result in severe personal injury or death.

**⚠ CAUTION** alerts you to a hazard or unsafe practice that can result in personal injury or equipment damage.

Electricity, fuel, exhaust, moving parts and batteries present hazards which can result in severe personal injury or death.

## GENERAL PRECAUTIONS

- Keep children away from the genset.
- Do not use evaporative starting fluids. They are highly explosive.
- Do not step on the genset when entering or leaving the generator room. Parts can bend or break leading to electrical shorts or to fuel, coolant or exhaust leaks.
- To prevent accidental or remote starting while working on the genset, disconnect the negative (–) battery cable at the battery.
- Let the engine cool down before removing the coolant pressure cap or opening the coolant drain. Hot coolant under pressure can spray and cause severe burns.
- Keep the genset, drip pan and compartment clean. Oily rags can catch fire. Gear stowed in the compartment can restrict cooling.

- Make sure all fasteners are secure and properly torqued.
- Do not work on the genset when mentally or physically fatigued or after having consumed alcohol or drugs.
- You must be trained and experienced to make adjustments while the genset is running—hot, moving or electrically live parts can cause severe personal injury or death.
- Used engine oil has been identified by some U. S. state and federal agencies as causing cancer or reproductive toxicity. Do not ingest, inhale, or contact used oil or its vapors.
- Ethylene glycol, used as engine antifreeze, is toxic to humans and animals. Clean up spills and dispose of used engine coolant in accordance with local environmental regulations.
- Keep multi-class ABC fire extinguishers handy. Class A fires involve ordinary combustible materials such as wood and cloth; Class B fires, combustible and flammable liquid fuels and gaseous fuels; Class C fires, live electrical equipment. (ref. NFPA No. 10)
- Genset installation and operation must comply with all applicable local, state and federal codes and regulations.

## GENERATOR VOLTAGE IS DEADLY

- Generator electrical output connections must be made by a trained and experienced electrician in accordance with applicable codes.
- The genset must not be connected to shore power or to any other source of electrical power. Back-feed to shore power can cause electric shock resulting in severe personal injury or death and damage to equipment. An approved switching device must be used to prevent interconnections.
- Use caution when working on live electrical equipment. Remove jewelry, make sure clothing and shoes are dry, stand on a dry wooden platform or rubber insulating mat and use tools with insulated handles.

### **ENGINE EXHAUST IS DEADLY**

- Never sleep in the boat while the genset is running unless the boat is equipped with properly working carbon monoxide detectors.
- The exhaust system must be installed in accordance with the genset Installation Manual and be free of leaks.
- Make sure the bilge is adequately ventilated with a power exhauster.
- Inspect for exhaust leaks every startup and after every eight hours of operation.
- For more information about carbon monoxide see American Boat and Yacht Council (ABYC) publication TH-22—*Educational Information About Carbon Monoxide*.

### **DIESEL FUEL IS COMBUSTIBLE**

- Do not smoke or turn electrical switches ON or OFF where fuel fumes are present or in areas sharing ventilation with fuel tanks or equipment. Keep flames, sparks, pilot lights, arc-producing equipment and all other sources of ignition well away.
- Fuel lines must be secured, free of leaks and separated or shielded from electrical wiring.

### **GASOLINE IS FLAMMABLE AND EXPLOSIVE**

- Because this genset is an *Ignition Protected* device, no substitutes are permitted for the parts listed in the *Critical Parts Index* of the genset Parts Catalog. They must be pur-

chased from Onan and be installed in accordance with the genset Service Manual by those who are trained and experienced in marine genset service.

### **BATTERY GAS IS EXPLOSIVE**

- Wear safety glasses.
- Do not smoke.
- To reduce arcing when disconnecting or reconnecting battery cables, always disconnect the negative (-) battery cable first and reconnect it last.

### **MOVING PARTS CAN CAUSE SEVERE PERSONAL INJURY OR DEATH**

- Do not wear loose clothing or jewelry near moving parts such as PTO shafts, fans, belts and pulleys.
- Keep hands away from moving parts.
- Keep guards in place over fans, belts, pulleys, and other moving parts.

### **FLAMMABLE VAPOR CAN CAUSE A DIESEL ENGINE TO OVERSPEED**

Flammable vapor can cause a diesel engine to overspeed and become difficult to stop, resulting in possible fire, explosion, severe personal injury and death. ***Do not operate a diesel-powered genset where a flammable vapor environment can be created by fuel spill, leak, etc.*** The owners and operators of the genset are solely responsible for operating the genset safely.

# **POST THESE SAFETY PRECAUTIONS IN POTENTIAL HAZARD AREAS OF THE BOAT**

# 1. Introduction

## ABOUT THIS MANUAL

This is the Operator's Manual for the generator sets (gensets) listed on the front cover. Each operator should study this manual carefully and observe all of its instructions and safety precautions. Keep this manual handy for ready reference.

**⚠WARNING** *This genset is not a life support system. It can stop without warning. Children, persons with physical or mental limitations, and pets could suffer personal injury or death. A personal attendant, redundant power or alarm system must be used if genset operation is critical.*

Operation, Periodic Maintenance and Troubleshooting provide the instructions necessary for operating the genset and maintaining it at top performance. The owner is responsible for performing maintenance in accordance with the PERIODIC MAINTENANCE SCHEDULE (p. 4-1). This manual also includes genset specifications, information on how to obtain service, and information regarding compliance with emissions regulations.

See the Parts Manual for part identification numbers and required quantities. Genuine Onan® replacement parts are recommended for best results.

## MODEL IDENTIFICATION

Be ready to provide the genset model and serial numbers on the nameplate when contacting Onan for parts, service and product information. Figure 1-1 illustrates the nameplate and its location on the side of the control box. Every character in these numbers is significant. (The last character of the model number is the specification letter, which is important for obtaining the right parts.) Record the genset model and serial numbers on the lines designated in the figure so that they are easy to find when you need them.

**⚠WARNING** *Because this genset is an Ignition Protected Device, no substitutes are permitted for the parts listed in the Critical Parts Index of the genset Parts Catalog. They must be purchased from Onan and be installed in accordance with the genset Service Manual by those who are trained and experienced in marine genset service.*

IMPORTANT ENGINE INFORMATION					
		CUMMINS POWER GENERATION 1400 73rd Ave. NE Minneapolis, MN 55432			
Model: <input type="text"/>	Spec: <input type="checkbox"/>	Made in U.S.A.			
S/N: <input type="text"/>	KVA: <input type="text"/>	Pf: <input type="text"/>	KW: <input type="text"/>	PH: <input type="text"/>	RPM: <input type="text"/>
	50 Hz: <input type="text"/>	<input type="text"/>	<input type="text"/>	<input type="text"/>	<input type="text"/>
	60 Hz: <input type="text"/>	<input type="text"/>	<input type="text"/>	<input type="text"/>	<input type="text"/>
As Manufactured:					
Freq: <input type="text"/>	AC Volts: <input type="text"/>	Amps: <input type="text"/>			
Options: <input type="text"/>	Fuel: <input type="text"/>	Bat: <input type="text"/>			
	Software Cfg: <input type="text"/>	Wire Diagram: <input type="text"/>			
Insulation - NEMA Class <input type="text"/> Ambient 40°C					
REFER TO OPERATOR'S MANUAL FOR MAINTENANCE SPECIFICATIONS AND ADJUSTMENTS.					
99-2495 <input type="checkbox"/>					

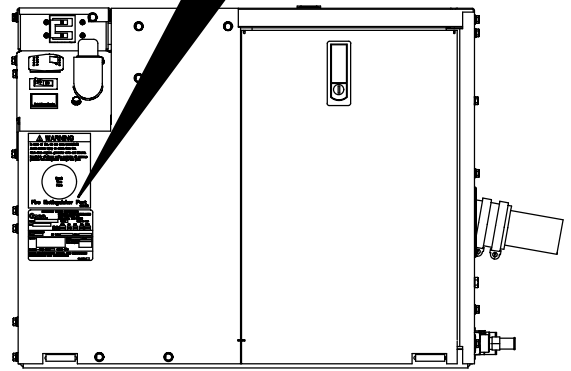
MODEL NUMBER: \_\_\_\_\_

SERIAL NUMBER: \_\_\_\_\_

FIGURE 1-1. TYPICAL NAMEPLATE

## HOW TO OBTAIN SERVICE

**⚠WARNING** *Improper service or replacement of parts can lead to severe personal injury or death and to damage to equipment and property. Service personnel must be qualified to perform electrical and mechanical service.*

For genset parts, service, and product information (such as the Service Manual), contact the nearest authorized Onan distributor. You may go to Internet site **www.onan.com** for information for contacting our distributors worldwide.

### In North America

Call 1-800-888-ONAN for the nearest Cummins/Onan distributor in the United States or Canada. Press 1 (OPTION 1) to be automatically connected.

If you are unable to contact a distributor using the automated service, consult the Yellow Pages. Typically, our distributors are listed under:

GENERATORS – ELECTRIC

### Outside North America

Call Onan Corporation at 1-763-574-5000 from 7:30 AM to 4:00 PM (Central Standard Time), Monday through Friday, or fax 1-763-528-7229.

### Information To Have Available

1. *Model Number, including Spec Letter, and Serial Number (Figure 1-1).*
2. *Date of purchase.*
3. *Nature of problem (Section 5. Troubleshooting).*

## EMISSIONS LABEL

The engine has a label on the air intake (Figure 1-2) which states compliance with applicable EPA and California emissions regulations.

California users of this genset should be aware that unauthorized modifications or replacement of fuel, exhaust, air intake, or speed control system components that affect engine emissions are prohibited. Unauthorized modification, removal or replacement of the engine label is prohibited.

You should carefully review Operator (Owner), Installation and other manuals and information you received with your genset. If you are unsure that the installation, use, maintenance or service of your genset is authorized, you should seek assistance from an approved Onan dealer.

California genset users may use Table 1-1 as an aid in locating information about the California Air Resources Board requirements for emissions control.

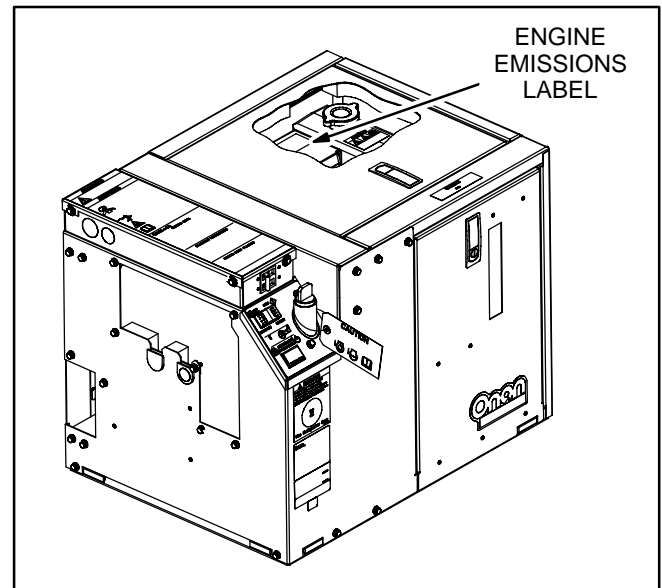

FIGURE 1-2. EMISSIONS LABEL

TABLE 1-1. EMISSIONS CONTROL INFORMATION

Emissions Warranty Information	The California emissions control warranty statement is located in the same packet of information as this manual when the genset is shipped from the factory.
Engine Fuel Requirements	The engine is certified to operate on diesel fuel. See FUEL RECOMMENDATIONS (Page 3-1).
Engine Lubricating Oil Requirements	See ENGINE OIL RECOMMENDATIONS (Page 3-1).
Engine Adjustments	High Idle Speed. This is a service procedure requiring trained personnel and proper tools. See the Service Manual.
Engine Emission Control System	The engine emission control system consists of engine design and precision manufacture. (IFI)

## 2. Control Panels

### LOCAL CONTROL PANEL

Refer to Figure 2-1.

#### Control Switch

**Starting:** Push and Hold **START** to preheat, crank and start the genset. The green lamp comes on when the genset is running. (Preheat is the period of time prior to engine cranking when the glow plugs preheat the combustion chambers. The time is automatically varied by the genset controller on the basis of engine temperature.)

**Stopping:** Push and Release **STOP (Prime)** to stop the genset.

**Priming:** Push and Hold **STOP (Prime)** to prime the fuel system (amber lamp comes on in 2 seconds to indicate priming).

#### Status Lamps

The control switch has two status lamps. The *amber* status lamp comes on during priming, blinks rapidly during cranking and goes out when the engine is up to speed. If the genset shuts down abnormally, this lamp will slowly blink a numerical code to indicate the cause of shutdown. See *Section 5. Troubleshooting*. The *green* status lamp comes on to indicate that the genset is running.

#### Emergency Stop Switch

In an emergency push the switch to **OFF**. Push it to **ON** after all necessary repairs to the genset and connected equipment have been made.

#### Line Circuit Breaker

The line circuit breaker protects the AC power leads connected to the genset from overloads and equipment short circuits.

#### Hour Meter

The hour meter records genset operating time in hours. It cannot be reset.

### REMOTE CONTROL AND MONITORING

#### Remote Control

The boat may be equipped with several remote control stations having e-Series Digital Displays (p. 2-2) or control switches with status lamps.

#### Boat Monitoring System

The boat may be equipped to monitor genset operation on an integrated monitoring system using an SAE J1939 or SmartCraft™ network protocol.

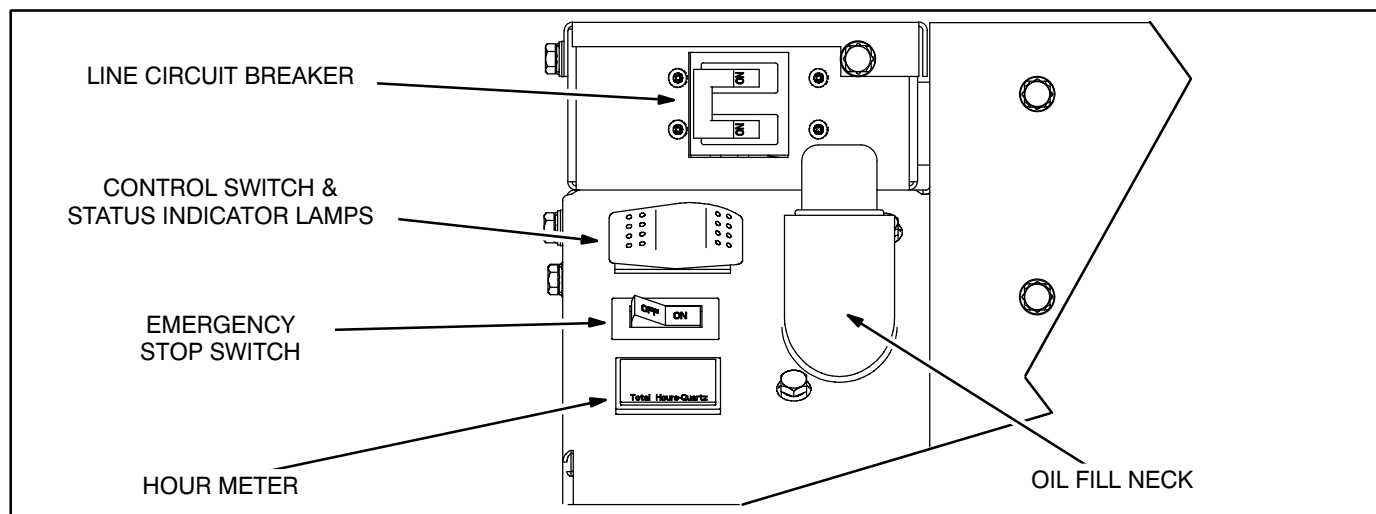

FIGURE 2-1. LOCAL CONTROL PANEL

## DIGITAL DISPLAY

The e-Series Digital Display has an LCD screen with 4 navigation buttons, 3 status lamps, a START button and a STOP button (Figure 2-2).

### Turning On the Display

Touch any button to turn on the Display, which will initialize and attempt to establish communications with the genset controller. All connected Displays will turn on automatically when the genset is started at any station. They will all turn off 5 minutes after the genset has received a normal command to stop. They will stay on indefinitely until a fault shutdown is cleared by touching any button on any Display.

### Start Button

**Starting the Genset:** Push and Hold **START** until the genset starts. The GENSET status lamp blinks while the engine is cranking. It comes on when the genset starts and stays on while it runs. The status displayed on the LCD changes from *Starting* to *Running* (Figure 2-3). See STARTING THE GENSET (p. 3-3).

### Stop Button

**Stopping the Genset:** Push and Release **STOP**. The GENSET status lamp will go out. The status displayed on the LCD will change from *Running* to *Stopped* (Figure 2-3). See STOPPING THE GENSET (p. 3-4).

**Priming the Fuel System:** Push and Hold **STOP**. The GENSET status lamp will blink. The status displayed on the LCD will change to *Priming* in 2 seconds (Figure 2-3). See PRIMING THE FUEL SYSTEM (p. 3-3).

### Genset Status Lamps

**GENSET** – This status lamp (green) blinks while the engine is cranking or the fuel system is being primed. It stays on while the genset is running.

**PRE-ALARM** – This status lamp (amber) comes on when an engine Pre-Alarm condition exists (p. 2-5).

**ALARM** – This status lamp (red) blinks during fault shutdown (p. 2-4).

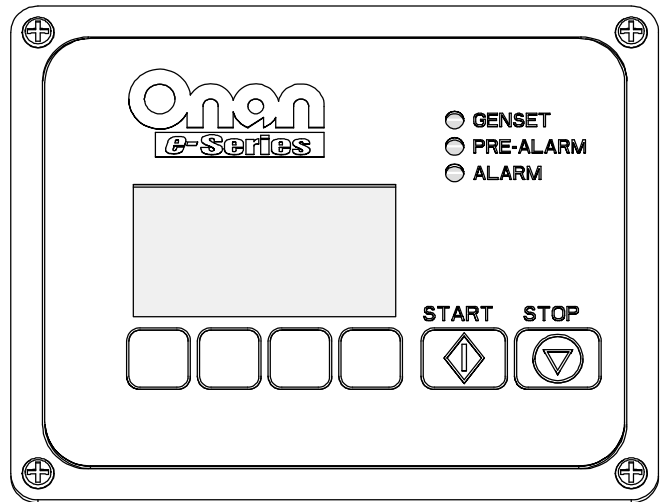

FIGURE 2-2. DIGITAL DISPLAY

## Genset Status

Genset status is displayed on 3 screen pages (Figure 2-3). GEN STATUS PG1 appears when the Display is turned on. Press the double arrows [↕] to toggle between the 3 screen pages.

The *Status* line on PG1 will display the word *Priming*, *Starting*, *Running*, *Stopped*, or *Volt Adj*. The rest of the lines on the 3 status screen pages display AC output voltage, AC frequency, engine coolant temperature, engine oil pressure, starting battery voltage and total genset running time.

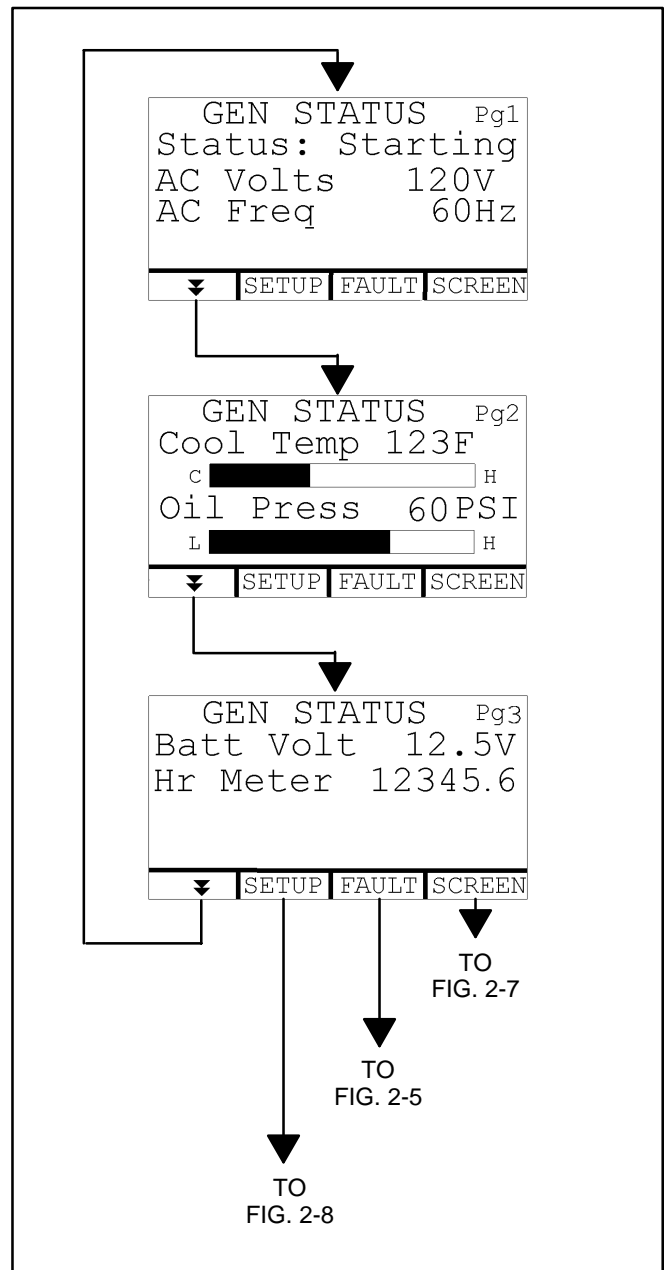

FIGURE 2-3. TYPICAL GENSET STATUS SCREENS

## Fault Screen

If a fault shutdown occurs the ALARM status lamp will blink and the LCD screen will display the Fault Number, a description of the Fault and the hour in total genset running time when the Fault occurred (Figure 2-4). Refer to TABLE 5-1. TROUBLESHOOTING GENSET FAULTS to diagnose and correct the problem.

The *e-Series Digital Display* will display the fault indefinitely. Touch any button to clear the fault. The display will turn off in 5 minutes after the fault has been cleared.

Press [◀BACK] to go back to the GEN STATUS screen.

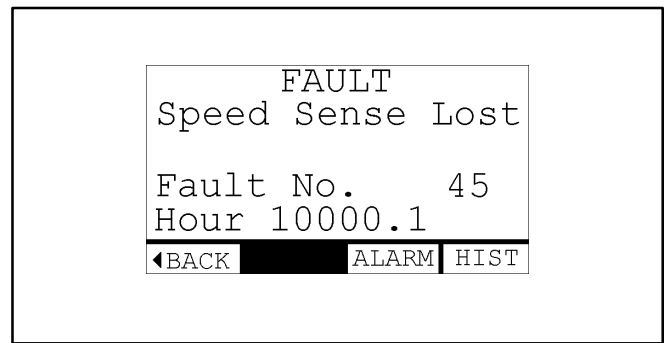

**FIGURE 2-4. TYPICAL FAULT SCREEN**

## Fault History

To display any of the last five faults, press the FAULT button on any GEN STATUS screen. Then press the HIST button on the FAULT screen (Figure 2-5).

The FAULT HISTORY screen will display the last Fault Number, a description of the Fault and the hour in total genset running time when the fault occurred. Press the double arrows [↕] to toggle between the last 5 faults. If there are no faults, the FAULT HISTORY screen will display *No Stored Faults*.

Press [←BACK] to go back to GEN STATUS.

## Engine Pre-Alarms

The PRE-ALARM status lamp will start to blink when engine oil pressure or temperature approaches its limit for engine shutdown. The Display will display *Low Oil Pressure* or *High Engine Temperature* on the PRE-ALARM screen (Figure 2-6).

Press [←BACK] to go back to GEN STATUS to monitor the engine temperature or oil pressure.

Service the genset as required.

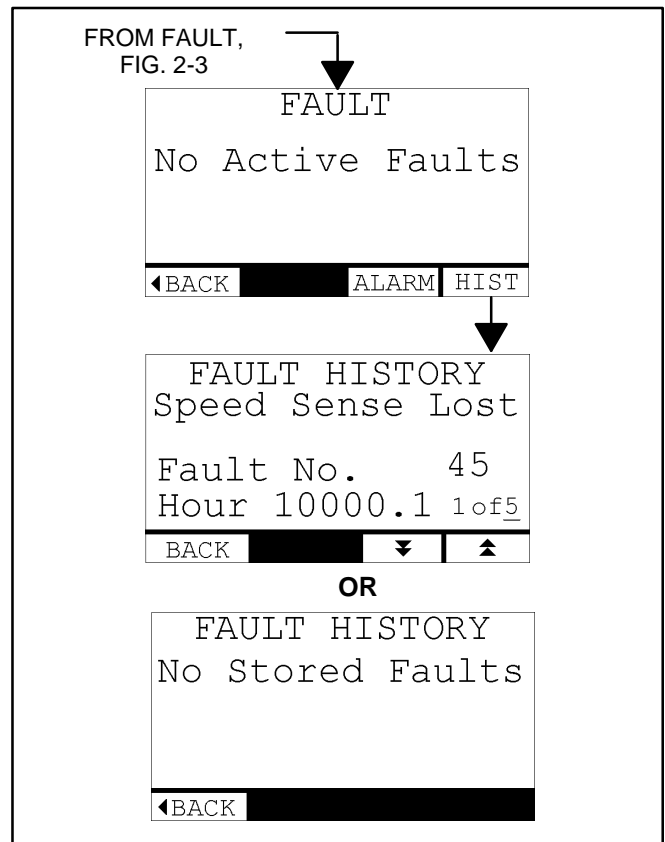

FIGURE 2-5. FAULT HISTORY

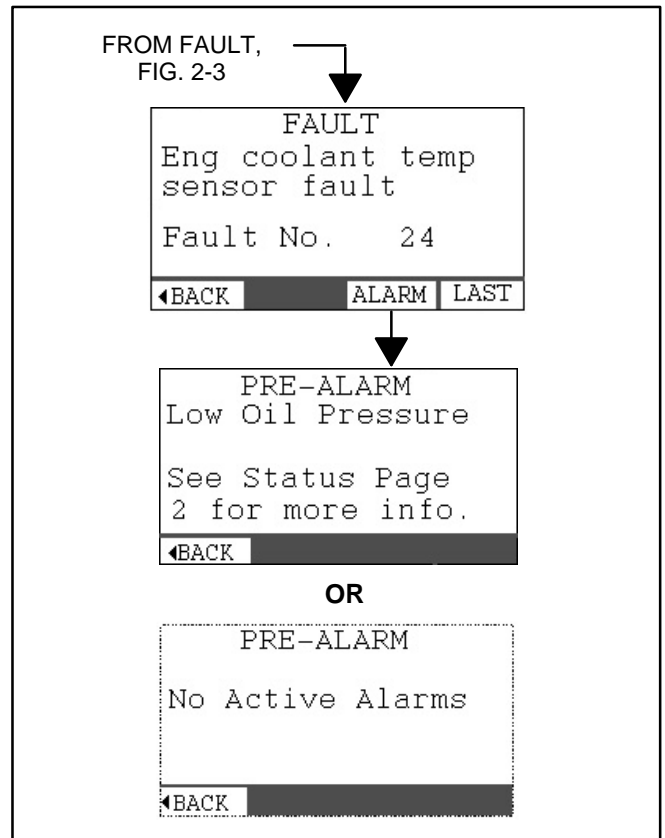

FIGURE 2-6. ENGINE PRE-ALARMS

## Brightness and Contrast

To adjust the brightness and contrast of the LCD screen and status lamps, go to the SCREEN ADJUST screen by pressing SCREEN on any GEN STATUS screen. Press NEXT to select *Brightness* or *Contrast*. Increase or decrease the selected item by pressing the increase-decrease buttons [◀ ▶]. See Figure 2-7. (“Contrast” applies only to the LCD screen.)

Press [◀BACK] to save the settings and go back to GEN STATUS.

## Display Setup

Go to the SETUP screen by pressing SETUP on any GEN STATUS screen. Press the up-down arrows [▼ ▲] to select *Display Setup* and press ENTER. See Figure 2-8.

**Units:** To change the units of measure on the GEN STATUS screens, press NEXT to select Units. Then press the up-down arrows [▼ ▲] to toggle between Metric and SAE units.

Press [◀BACK] to save the selection and go back to GEN STATUS.

**AC Voltmeter Calibration:** To calibrate the Display Voltmeter, press NEXT to select AC Voltmeter Calibration. Then press the up-down arrows [▼ ▲] to increase or decrease the voltage displayed to correspond to an accurate AC output voltmeter (line-to-line or line-to-neutral, as desired).

Press [◀BACK] to save the selection and go back to GEN STATUS.

**Note:** This procedure does not change AC output voltage. Have a trained and experienced person adjust AC output voltage, if necessary, before calibrating the Display Voltmeter.

## Genset and Display Information

Go to the SETUP screen by pressing SETUP on any GEN STATUS screen. Press the up-down arrows [▼ ▲] to select *Genset Info* or *Display Info* and press ENTER. See Figure 2-8. This information may be requested by the service technician.

Keep pressing [◀BACK] to get back to GEN STATUS.

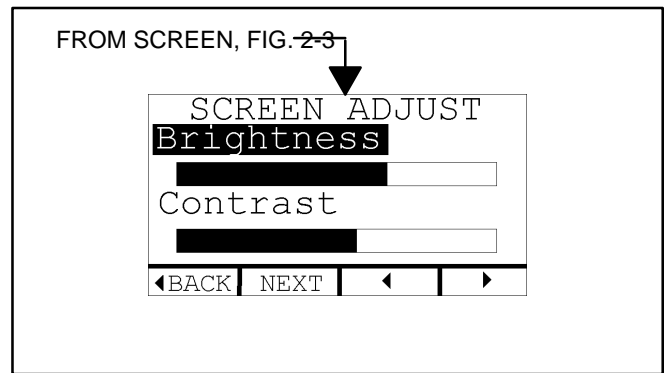

FIGURE 2-7. SCREEN BRIGHTNESS & CONTRAST

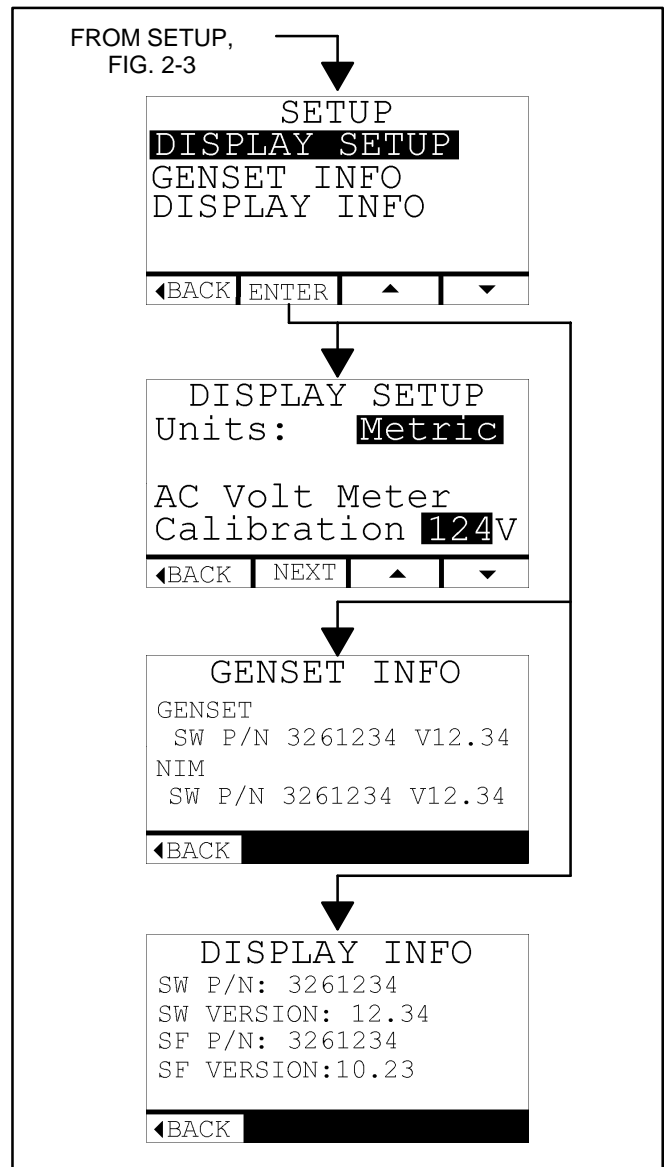

FIGURE 2-8. SETUP, GENSET & DISPLAY INFO

# 3. Operation

## FUEL

**⚠WARNING** Diesel fuel is combustible and can cause severe personal injury or death. Do not smoke near fuel tanks or fuel-burning equipment or in areas sharing ventilation with such equipment. Keep flames, sparks, pilot flames, electrical arcs and switches and all other sources of ignition well away. Keep a multi-class ABC fire extinguisher handy.

High quality Grade 2-D diesel fuel is necessary for good performance and long engine life. Diesel fuels specified by EN 590 or ASTM D975 are recommended. Use Grade 1-D diesel fuel if the fuel tank is exposed to temperatures below 40° F (5° C).

The Cetane number should not be less than 45 and sulfur content not more than 0.5 percent (by weight). Where fuel is exposed to cold ambient temperatures, use fuel that has a cloud point (temperature at which wax crystals begin to form) at least 10° F (6° C) degrees below the lowest expected fuel temperature.

Fuel lubricity should pass a minimum load level of 3100 grams as measured by ASTM D6078 or maximum scar diameter of 0.45 mm as measured by ASTM D6079 or ISO 12156-1.

## ENGINE OIL

Use API (American Petroleum Institute) Service Category **CI-4** engine oil or better. Also look for the SAE (Society of Automotive Engineers) viscosity grade. Referring to Figure 3-1, choose the viscosity grade appropriate for the ambient temperatures expected until the next scheduled oil change. Multi-grade oils such as SAE 15W-40 are recommended for year-round use.

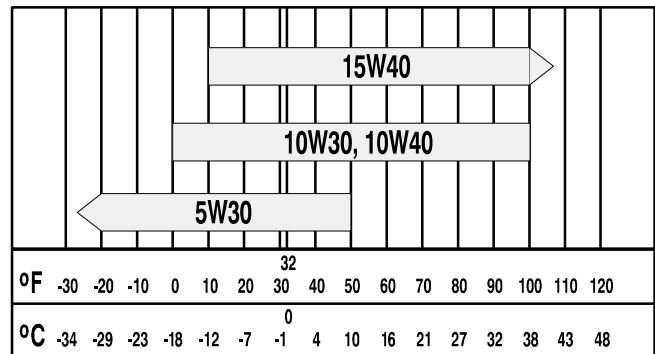

FIGURE 3-1. OIL VISCOSITY GRADE VS. AMBIENT TEMPERATURE

## ENGINE COOLANT

Use the best quality ethylene glycol antifreeze solution available. It should be fully formulated with rust inhibitors and coolant stabilizers. A 50/50 mixture of water and ethylene glycol is recommended to provide protection from freezing down to  $-34^{\circ}\text{F}$  ( $-37^{\circ}\text{C}$ ).

Use fresh water that is low in minerals and corrosive chemicals for the coolant mixture. Distilled water is best.

See *Section 6. Specifications* regarding coolant capacity.

**⚠WARNING** *Ethylene Glycol antifreeze is considered toxic. Dispose of it according to local regulations for hazardous substances.*

## BATTERIES

Reliable genset starting and starter service life depend upon adequate battery system capacity and maintenance. See MAINTAINING THE BATTERY AND BATTERY CONNECTIONS (p. 4-2) and *Section 6. Specifications*.

## FIRE EXTINGUISHER PORT

A genset with an enclosure has a fire extinguisher port accessible by breaking through the circle on the warning label located as shown in Figure 3-2. ***Make sure that the nozzle of the fire extinguisher that will be used in the event of fire is smaller than the circle so that it will fit through the port.*** The fire extinguisher must be of the gaseous type.

In the event of fire:

1. DO NOT open the genset enclosure.
2. Shut down engines, generators and blowers.
3. Break through the circle on the label with the nozzle and discharge the full contents of the fire extinguisher.

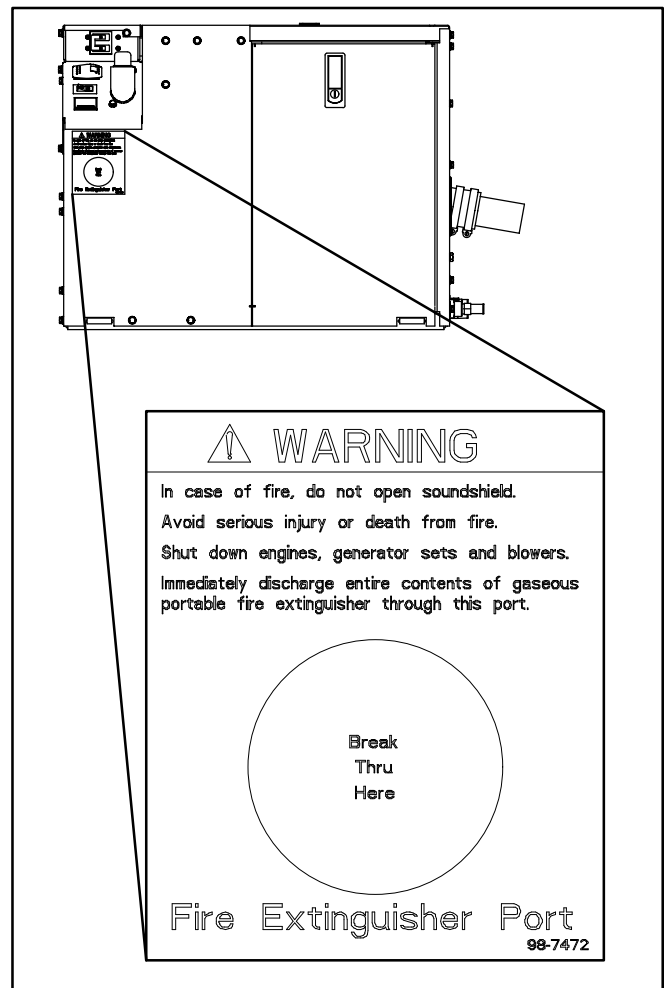

FIGURE 3-2. FIRE EXTINGUISHER PORT

**⚠WARNING** **EXHAUST GAS IS DEADLY.** All engine exhaust contains carbon monoxide; an odorless, colorless, poisonous gas that can cause unconsciousness and death. Symptoms of carbon monoxide poisoning include:

- **Dizziness**
- **Headache**
- **Nausea**
- **Weakness and Sleepiness**
- **Vomiting**
- **Inability to Think Coherently**

**GET EVERYONE OUT INTO FRESH AIR IMMEDIATELY IF ANYONE EXPERIENCES ANY OF THESE SYMPTOMS. Seek medical attention if symptoms persist. Never sleep in the boat when the genset is running, unless the cabin has a working carbon monoxide detector.**

**Look over the entire exhaust system and listen for leaks every time you start up the genset and after every eight hours of operation. Shut down the genset immediately if there is a leak. Do not run the genset until the leak has been repaired. The exhaust system must be installed in accordance with the genset Installation Manual.**

### PRE-START CHECKS

Before the first start of the day and after every eight hours of operation, inspect the genset as instructed under GENERAL INSPECTION (p. 4-2). Keep a log of maintenance and the hours run and perform any maintenance that may be due. See Returning the Genset to Service (p. 3-6) if the boat has been in storage. Before each start:

1. Make sure all CO detectors on board are working properly.
2. Check for swimmers that might be exposed to the engine exhaust.
3. Disconnect all electrical loads and disengage the PTO (if so equipped).

### PRIMING THE FUEL SYSTEM

The fuel system should be primed after replacing the fuel filter or running the genset out of fuel. To prime the fuel system, *Push and Hold STOP* on the e-Series Digital Display or **STOP (Prime)** on the control switch for at least 30 seconds.

### STARTING THE GENSET

The genset can be started and stopped from the genset control panel or remote control panel.

1. *Push and Hold START* on the e-Series Digital Display or control switch until the genset starts. The genset status lamp blinks when the engine is cranking and comes on and stays on when the genset starts and runs. The status displayed on the e-Series Digital Display changes from *Starting* to *Running* (Figure 2-3).
2. For longer engine life, let the engine warm up for two minutes before connecting air conditioners and other large electrical loads or engaging the PTO (if so equipped).
3. Check for water, coolant, fuel and exhaust leaks. Stop the genset immediately if there is a leak. Repair fuel leaks immediately.
4. Monitor generator set status using the e-Series Digital Display (p. 2-3), if so equipped. Perform maintenance or service as necessary if the Display indicates a **Pre-Alarm** condition (p 2-2).
5. **If the genset fails to start**, cranking will discontinue in 20 to 60 seconds, depending on engine temperature. The e-Series Digital Display and/or control switch status lamp will indicate Fault Code No. 4. See *Troubleshooting* (Sec. 5) if the genset does not start after several tries.

**⚠CAUTION** **Do not continue cranking and risk burning out the starter or flooding the engine (exhaust flow during cranking is too low to expel water from a wet exhaust system). Find out why the genset does not start and make necessary repairs.**

6. **If the genset shuts down**, the e-Series Digital Display and/or control switch status lamp will indicate the numeric fault code. See *Troubleshooting* (Sec. 5).

## STOPPING THE GENSET

Disconnect all electrical loads and disengage the PTO (if so equipped) to let the genset run without load and cool down. After 2 minutes *Push* and *Release* **STOP** on the e-Series Digital Display or control switch. The genset status lamps will go out.

## EMERGENCY STOP

Push the **EMERGENCY STOP SWITCH** to **OFF** (p. 2-1). After all necessary repairs have been made, push the switch to **ON** so that the genset can be operated.

## LOADING THE GENSET

How much equipment load can be powered depends upon the genset power rating. The genset will shut down or its AC output circuit breakers will trip if the sum of the loads exceeds genset power or circuit breaker rating.

To avoid overloading the genset and causing shutdowns, compare the sum of the loads of the appliances that are likely to be used at the same time with the power rating of the genset. Use Table 3-2 or the ratings on the appliances themselves to obtain the individual appliance loads. If the appliance is marked in amps and volts only, multiply the amps times the volts to obtain the appliance load (watts). ***It may be necessary to run fewer appliances at the same time—the sum of the loads must not be greater than genset rating.***

The genset may shut down due to overload when a large motor or air conditioner is started or cycles off and then on again, even though the sum of the loads is less than genset rating. The reason for this is that a motor's startup load is much larger than its running load. ***It may be necessary to run fewer loads when large motors and air conditioners are cycling on and off.***

The genset is rated at standard barometric pressure, humidity and temperature (ref. ISO 3046). Either low barometric pressure (high altitude) or high ambient temperature will decrease engine power. ***It may be necessary to run fewer loads under such conditions.***

TABLE 3-1. TABLE 3-2. TYPICAL APPLIANCE LOADS

Appliance	Load (watts)
Air Conditioner	1400-2000
Battery Charger	Up to 3000
DC Converter	300-700
Refrigerator	600-1000
Microwave Oven	1000-1500
Electric Frying Pan or Wok	1000-1500
Electric Stove Element	350-1000
Electric Water Heater	1000-1500
Electric Iron	500-1200
Electric Hair Dryer	800-1500
Coffee Percolator	550-750
Television	200-600
Radio	50-200
Electric Drill	250-750
Electric Broom	200-500
Electric Blanket	50-200

## NO-LOAD OPERATION

**Keep no-load operation to a minimum.** During no-load operation cylinder temperatures drop to the point where fuel does not burn completely, causing fuel wetting and white smoke. It is best to run the genset at 1/4 to 3/4 load.

## RESETTING LINE CIRCUIT BREAKERS

If the genset line circuit breaker trips (p. 2-1), or a circuit breaker in the power distribution panel of the boat, either a circuit shorted or too many loads were connected. Note that the genset will continue to run after a line circuit breaker trips.

If a circuit breaker trips, disconnect or turn off as many loads as possible and reset the circuit breaker. If the circuit breaker trips right away, either the electrical distribution system has a short or the circuit breaker is faulty. Call a qualified electrician.

If the circuit breaker does not trip, reconnect loads one-by-one up to a total load that does not overload the genset or cause the circuit breaker to trip. The circuit probably has a short if the circuit breaker trips right away when it is connected.

Electrical equipment must be used and maintained properly and be properly grounded to cause the line circuit breakers to trip when short circuits occur.

**▲WARNING** *Short circuits in electrical equipment can cause fire and electrical shock leading to severe personal injury or death. Electrical equipment and its grounding must be maintained properly to protect against short circuits.*

## CONNECTING TO SHORE POWER

When provisions have been made for connecting shore power, the boat must have an approved device to keep the genset and shore power from being interconnected.

**▲WARNING** *Interconnecting the genset and shore power can lead to electrocution of utility line workers, equipment damage and fire. Use an approved switching device to prevent interconnections.*

## COLD TEMPERATURE OPERATION

Do not let raw water freeze in the heat exchanger during cold weather when the genset is not operating. Freezing water can damage the raw water tubes in the heat exchanger. Engine coolant, but not raw water, is protected from freezing. If freezing temperatures are expected, see Heat Exchanger under *Periodic Maintenance* (p. 4-12). Also drain the muffler.

## CARE OF NEW OR RE-BUILT ENGINE

Avoid no-load operation as much as possible during break-in. Change the oil and oil filter after the first 50 hours of operation (p. 4-4).

## EXERCISING THE GENSET

Exercise the genset at least 1 hour every month if use is infrequent. Run the genset at 1/4 to 3/4 load. A single exercise period is better than several shorter periods. Exercising a genset drives off moisture, re-lubricates the engine, uses up fuel before it becomes stale and removes oxides from electrical contacts. The result is better starting, more reliable operation and longer engine life.

## STORING THE GENSET

Proper storage is essential for preserving top genset performance and reliability when the genset cannot be exercised regularly and will be idle for more than 120 days.

### Storing the Genset

1. Turn off the genset line circuit breaker (p. 2-1).
2. Change the engine oil and filter and attach a tag indicating oil viscosity. See ENGINE OIL RECOMMENDATIONS (p. 3-1).
3. Crank the engine several revolutions but do not let it start. This will fill the oil passages with the new oil.
4. Disconnect the battery cables (negative [-] cable first) from the starting battery and store the battery according to the battery manufacturer's recommendations. See MAINTAINING THE BATTERY AND BATTERY CONNECTIONS (p. 4-2).
5. Check coolant level and add as necessary (p. 4-6). Test the coolant mixture if freezing temperatures are possible and change if necessary.

**⚠WARNING** *Hot coolant is under pressure and can cause severe burns when loosening the pressure cap. Let the engine cool before loosening the pressure cap.*

6. If freezing temperatures are expected, see Heat Exchanger under *Periodic Maintenance* (p. 4-12). Also drain the muffler.
7. Clean and lightly oil parts that can rust.

### Returning the Genset to Service

1. Check the oil tag on the genset and change the oil if the viscosity indicated is not appropriate for the temperatures expected. See ENGINE OIL RECOMMENDATIONS (p. 3-1).
2. Reconnect the starting battery (negative [-] cable last). See MAINTAINING THE BATTERY AND BATTERY CONNECTIONS (p. 4-2).
3. Replace the raw water pump impeller if it was installed more than a year ago (p. 4-10).
4. Perform the maintenance required (p. 4-1), conduct the pre-start checks and prime the fuel system.
5. Start and run the genset.
6. Turn on the genset line circuit breaker (p. 2-1) when ready to power loads.

# 4. Periodic Maintenance

Periodic maintenance is essential for top performance and long genset life. Use Table 4-1 as a guide for normal periodic maintenance.

Maintenance, replacement or repair of emission control devices and systems may be performed by any engine repair establishment or individual. However, warranty work must be completed by an authorized Onan service representative.

To help you keep genset maintenance regular and provide a basis for warranty claims, record maintenance performed in *Maintenance Record* (p. 7-1).

**⚠️WARNING** *Accidental or remote starting can cause severe personal injury or death. Disconnect the negative (-) cable at the battery to prevent starting while working on the genset.*

**TABLE 4-1. PERIODIC MAINTENANCE SCHEDULE**

MAINTENANCE OPERATION	MAINTENANCE FREQUENCY								Page
	After First 50 Hrs	Every Day / 8 Hrs	Every Month/ 100 Hrs	Every Year/ 200 Hrs	Every Year/ 500 Hrs	Every 800 Hrs	Every 2 Years	Every 5 Years/ 2000 Hrs	
General Inspection <sup>1</sup>		•							4-2
Check Engine Oil Level		•							4-3
Drain Water from Fuel Filter			•						4-5
Inspect Battery and Battery Connections <sup>2</sup>			•						4-2
Check V-Belt Tension <sup>3</sup>			•						4-9
Inspect Siphon Break			•						4-8
Change Engine Oil and Oil Filter	•			•					4-4
Replace Fuel Filters					•				4-5
Replace Raw Water Impeller					•				4-10
Adjust Engine Valve Lash <sup>5</sup>						•			–
Replace Coolant, Pressure Cap & Thermostat <sup>4</sup>							•		4-6
Check Generator Bearings, Drive Belt, Belt Tensioner & Drive Coupling <sup>5</sup>								•	–

1 – Includes inspection of Oil Level, Coolant Level, Fuel System, Exhaust System, Batteries and Battery Connections.  
 2 – See battery manufacturer's recommendations.  
 3 – Check for slippage, cracking and wear (pump drive belt only).  
 4 – There is no zinc anode to replace.  
 5 – Must be performed by a qualified mechanic (authorized Onan dealer) in accordance with the engine and genset Service Manuals..

## GENERAL INSPECTION

Inspect the genset before the first start of the day and after every eight hours of operation.

### Oil Level

Check engine oil level (p. 4-3).

### Exhaust System

Inspect the exhaust system for leaks and loose hose clamps at the exhaust manifold, exhaust elbow, muffler, water separator and hull fittings. Replace damaged sections of exhaust hose.

Check that all CO monitors are working properly.

**▲WARNING** *EXHAUST GAS IS DEADLY! Do not operate the genset until all exhaust leaks have been repaired.*

### Fuel System

Check for leaks at hose, tube and pipe fittings in the fuel supply and return systems while the genset is running and while it is stopped. Check flexible fuel hose for cuts, cracks, abrasions and loose hose clamps. Make sure fuel lines do not rub against other parts. Replace worn or damaged fuel line parts before leaks occur. Replace hose with with USCG TYPE A1 or ISO 7840-A1 fuel hose.

Prime the fuel system if the genset ran out of fuel.

**▲WARNING** *Fuel leaks can lead to fire. Repair leaks immediately. Do not run the genset if it causes fuel to leak.*

### Coolant Level

Check coolant level in the recovery tank and, if necessary, refill to COLD when the engine is cold or to HOT when it is at normal running temperature. The recovery tank is designed to maintain coolant level, not to fill the system. If the tank is empty, check for and repair any coolant leaks and refill the system through the fill neck on the engine. See Refilling the Cooling System (p. 4-6). Use the recommended antifreeze mixture (p. 3-2).

### Raw Water System

Clean out the sea water strainer if necessary and make sure the sea cock is open for genset operation. Also, when a water/exhaust separator is pro-

vided (see Installation Manual), open the sea cock for the water drain hose.

Check for and replace hoses that leak or are damaged.

### Battery Connections

See MAINTAINING THE BATTERY AND BATTERY CONNECTIONS.

### Mechanical

Monitor generator set status using the e-Series Digital Display (p. 2-3).

Look for mechanical damage and listen for unusual noises when the genset is running. Check the genset mounting bolts. Check to see that the genset air inlet and outlet openings are not clogged with debris or blocked. Keep the genset compartment clean.

## MAINTAINING THE BATTERY AND BATTERY CONNECTIONS

**▲WARNING** *Arcing at battery terminals or in light switches or other equipment, and flames or sparks, can ignite battery gas causing severe personal injury—Ventilate battery area before working on or near battery—Wear safety glasses—Do not smoke—Switch work light ON or OFF away from battery—Stop genset and disconnect charger before disconnecting battery cables—Disconnect negative (–) cable first and reconnect last.*

Refer to Table 4-1 for scheduled battery maintenance, and follow the battery manufacturer's instructions. Have the battery charging system serviced if DC system voltage is consistently low or high.

Check the battery terminals for clean, tight connections. Loose or corroded connections have high electrical resistance which makes starting harder. Always:

1. Keep the battery case and terminals clean and dry and the terminals tight.
2. Use a battery terminal puller if the battery has terminal posts.
3. Make sure which terminal is positive (+) and which is negative (–) before making battery connections, always removing the negative (–) cable first and reconnecting it last to reduce arcing.

## CHECKING ENGINE OIL LEVEL

**⚠WARNING** *State and federal agencies have determined that contact with used engine oil can cause cancer or reproductive toxicity. Avoid skin contact and breathing of vapors. Use rubber gloves and wash exposed skin.*

**Crankcase pressure can blow hot engine oil out the fill opening causing severe burns. Always stop the genset before removing the oil fill plug.**

1. Pull the plug and dipstick out of the oil fill neck (Figure 4-1). The plug may be difficult to pull straight out. It is easier if you tilt the plug in its socket while pulling out. Wipe off the dipstick and thread it back into the fill neck and seat the plug, which snaps into its socket. Remove the plug and dipstick again and check the oil level on the dip stick.
2. Add or drain oil as necessary. See ENGINE OIL RECOMMENDATIONS (Page 3-1). Keep the oil level between the high and low beads on the end of the dipstick, as shown. It is not necessary to add oil between oil changes if the oil has not dropped more than 1/3 of the way between the high and low beads.

**⚠CAUTION** *Too little oil can cause severe engine damage. Too much oil can cause high oil consumption.*

3. Secure the oil fill plug, which snaps into its socket.

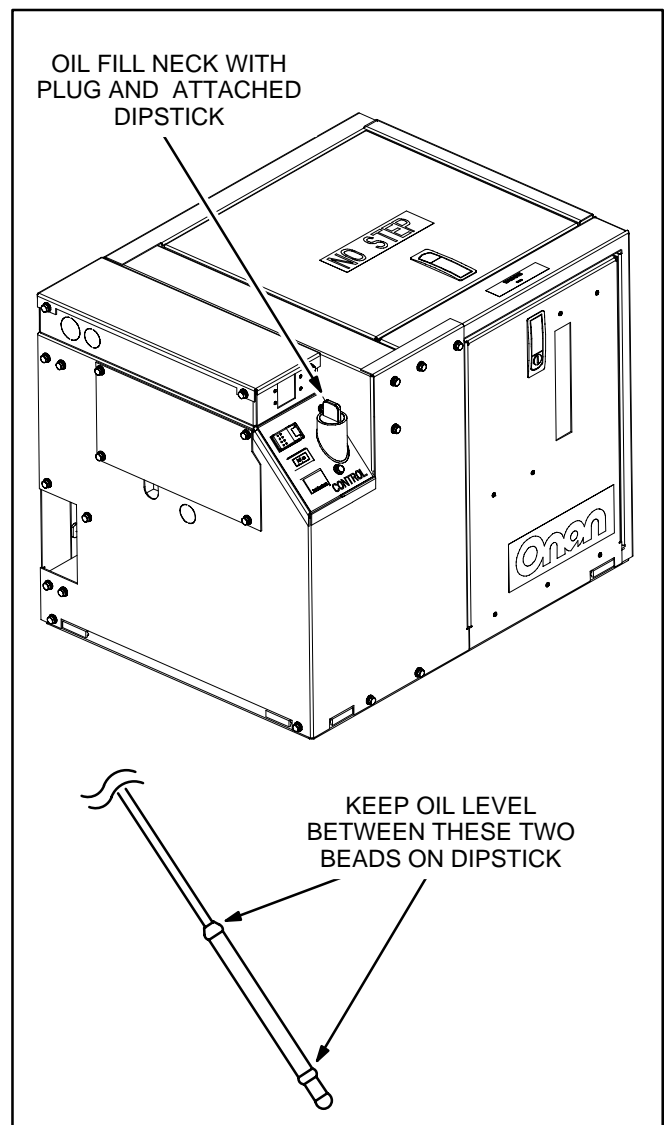

FIGURE 4-1. OIL FILL NECK AND DIPSTICK

## CHANGING ENGINE OIL AND FILTER

**⚠WARNING** State and federal agencies have determined that contact with used engine oil can cause cancer or reproductive toxicity. Avoid skin contact and breathing of vapors. Use rubber gloves and wash exposed skin.

**Crankcase pressure can blow hot engine oil out the fill opening causing severe burns. Always stop the genset before removing the oil fill plug.**

**⚠WARNING** Accidental or remote starting can cause severe personal injury or death. Disconnect the negative (-) cable at the battery to prevent the engine from starting.

Refer to Table 4-1 for scheduled engine oil change.

1. Run the genset under load until it is up to operating temperature, stop it and disconnect the negative (-) battery cable at the battery.
2. Remove the oil fill plug (Figure 4-1), open the front access door and drain the engine oil into a container by opening the drain valve (Figure 4-2). (The drain valve has a 3/8 NPT outlet for connecting a hose fitting to facilitate oil draining.) If an oil pump-out system is installed, follow the instructions provided.
3. Close the oil drain valve.
4. Spin off the old oil filter with a filter wrench and wipe off the filter mounting surface. (A filter wrench is available from Onan.) Remove the old gasket if it does not come off with the filter.
5. Apply a film of oil to the filter gasket and partly fill the filter with oil so that it reaches engine parts sooner at startup. Spin the new filter on by hand until the gasket just touches the mounting pad and tighten 3/4 turn.
6. Refill the engine with the proper type and amount of engine oil. See ENGINE OIL RECOMMENDATIONS (p. 3-1) and Specifications (p. 6-1). Check the oil level and add or drain oil as necessary.

**⚠CAUTION** Too little oil can cause severe engine damage. Too much oil can cause high oil consumption.

7. Close the access door and dispose of the used oil and oil filter according to local environmental regulations.

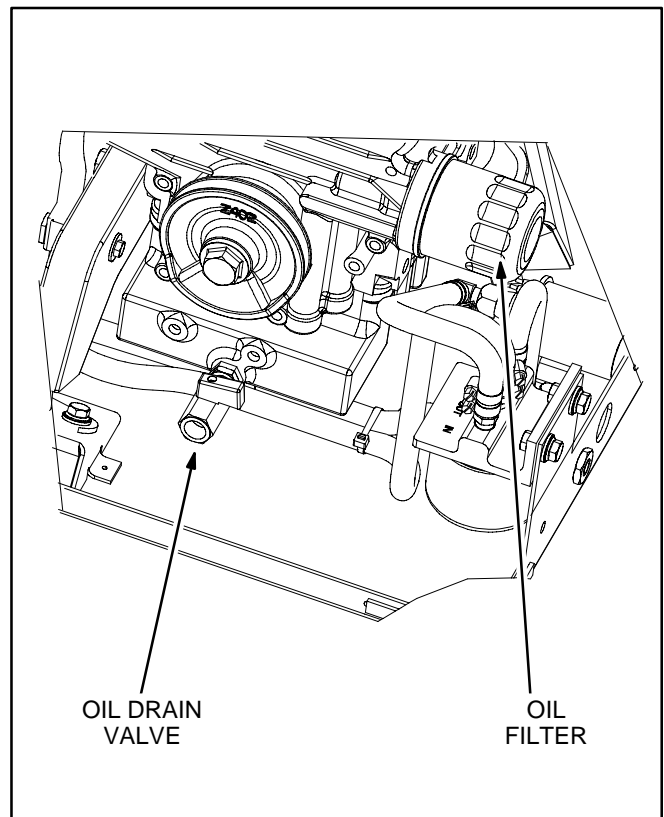

**FIGURE 4-2. OIL FILTER AND DRAIN VALVE**

## DRAINING/REPLACING THE FUEL FILTER

**⚠WARNING** Diesel fuel is combustible and can cause severe personal injury or death. Do not smoke near fuel tanks or fuel-burning equipment or in areas sharing ventilation with such equipment. Keep flames, sparks, pilot flames, electrical arcs and switches and all other sources of ignition well away. Keep a multi-class ABC fire extinguisher handy.

**⚠WARNING** Accidental or remote starting can cause severe personal injury or death. Disconnect the negative (–) cable at the battery to prevent the engine from starting.

Keep dirt, water and other contaminants from entering the fuel system and corroding or clogging fuel injection components.

The genset has a water-separator fuel filter (Figure 4-3). Check for other up-stream filters which may also need to be drained or replaced.

### Draining Water and Sediment

Drain water and sediment more often than scheduled (Table 4-1) if fuel quality is poor or condensation cannot be avoided.

1. Disconnect the negative (–) cable at the battery to prevent the engine from starting and close any fuel supply and return valves.
2. Open the front access door and drain the filter (about 1/2 cup [120 ml]) into a suitable container by removing the drain plug (bottom of filter).
3. Re-install the drain plug and dispose of the drain-off in accordance with local environmental regulations.

### Replacing Fuel Filter

See Table 4-1 for scheduled filter change. Change the filter if the engine lacks power.

1. Disconnect the negative (–) cable at the battery to prevent the engine from starting and close any fuel supply and return valves.
2. Open the front access door and spin off the old filter with a filter wrench and dispose of it in accordance with local environmental regulations.
3. Clean the contact surface on the filter base, lubricate the new filter gasket and spin the new filter on hand tight.
4. Prime the engine for at least 30 seconds (Page 3-3) to fill the new filter. Run the genset and check for leaks. Tighten the filter by hand, if necessary.

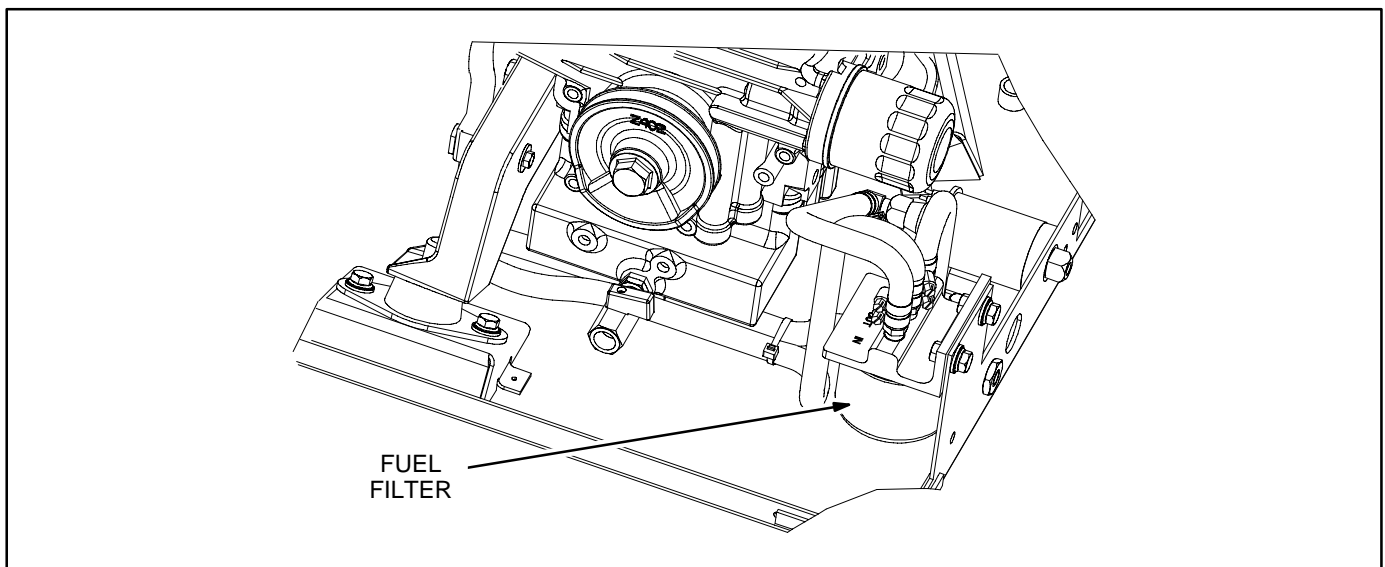

FIGURE 4-3. FUEL FILTER

## MAINTAINING THE ENGINE COOLING SYSTEM

Refer to Table 4-1 for scheduled maintenance.

### Cooling System Overview

The engine is cooled by a pressurized, closed-loop liquid cooling system in which coolant is pumped through passages in the engine block, head and exhaust manifold (Figure 4-4). The exhaust manifold also serves as the engine coolant reservoir.

The heat exchanger is mounted inside the exhaust manifold. Raw water (the flotation water) is pumped through tubes in the heat exchanger to cool the engine coolant. The raw water then passes through a hose into the exhaust-water mixer where it cools the exhaust gases and is expelled. The V-belt drives the coolant and the raw water pumps.

### Recommended Coolant Mixture

See ENGINE COOLANT (p. 3-2) for recommendations.

### Replenishing Normal Coolant Loss

Check coolant level in the recovery tank before the first startup of each day and, if necessary, refill to COLD when the engine is cold or to HOT when it is running. The recovery tank is designed to maintain coolant level, not to fill the system. If the tank is empty, check for and repair any coolant leaks and refill the system through the fill neck on the engine.

Make sure the two hoses from the recovery tank are routed through the two holes in the right end of the genset enclosure, that the coolant recovery hose is connected to the fill neck on the engine and that the overflow hose terminates in the drip pan where it will not splash coolant on electrical components.

### Pressure Cap

Replace the pressure cap every two years (seals deteriorate and leak). Proper cooling system pressure (10 psi) is essential for optimal engine cooling and minimal coolant loss.

### Coolant Hoses

Check for and replace hoses that leak or are damaged.

## Draining and Cleaning Cooling System

**⚠ WARNING** *Accidental or remote starting can cause severe personal injury or death. Disconnect the negative (–) cable from the battery to prevent the engine from starting.*

*Hot coolant spray can cause severe burns. Let the engine cool before releasing the pressure cap or removing the drain cap.*

1. Have towels and containers ready to wipe up, collect and properly dispose of the coolant.
2. Disconnect the negative (–) cable at the battery to prevent the engine from starting, let the engine cool and remove the front and top access doors and the coolant pressure cap.
3. Drain the exhaust manifold/coolant reservoir by disconnecting the hose at the coolant pump inlet (Figure 4-4) and twisting it down into a container.
4. Drain the block by removing the cap on the drain fitting on the left side of the block (Figure 4-4). Use an 11/16 inch socket on a swivel and 12 to 18 inch extension. To catch the coolant and direct it into a container, insert the socket and extension through a piece of hose large enough to fit over the socket but shorter than the extension. The hose will catch the coolant as the cap is being unscrewed.
5. Use radiator cleaning chemicals to clean and flush the cooling system before refilling with fresh coolant. Follow the cleaner manufacturer's instructions.

## Refilling Cooling System

Close the block drain cap and reconnect the pump inlet hose and fill the system through the engine fill neck. The system will fill only as fast as the air can escape. Fill to the bottom of the fill neck. Start and run the engine for a couple of minutes to dislodge air pockets and shut it down. Add as much coolant as necessary and secure the pressure cap. Then refill the recovery tank up to the COLD mark.

**⚠ CAUTION** *Low coolant level can cause severe engine damage. Make sure the system is full.*

*Filling a hot engine with cold water can cause cracks in the manifold, head and block.*

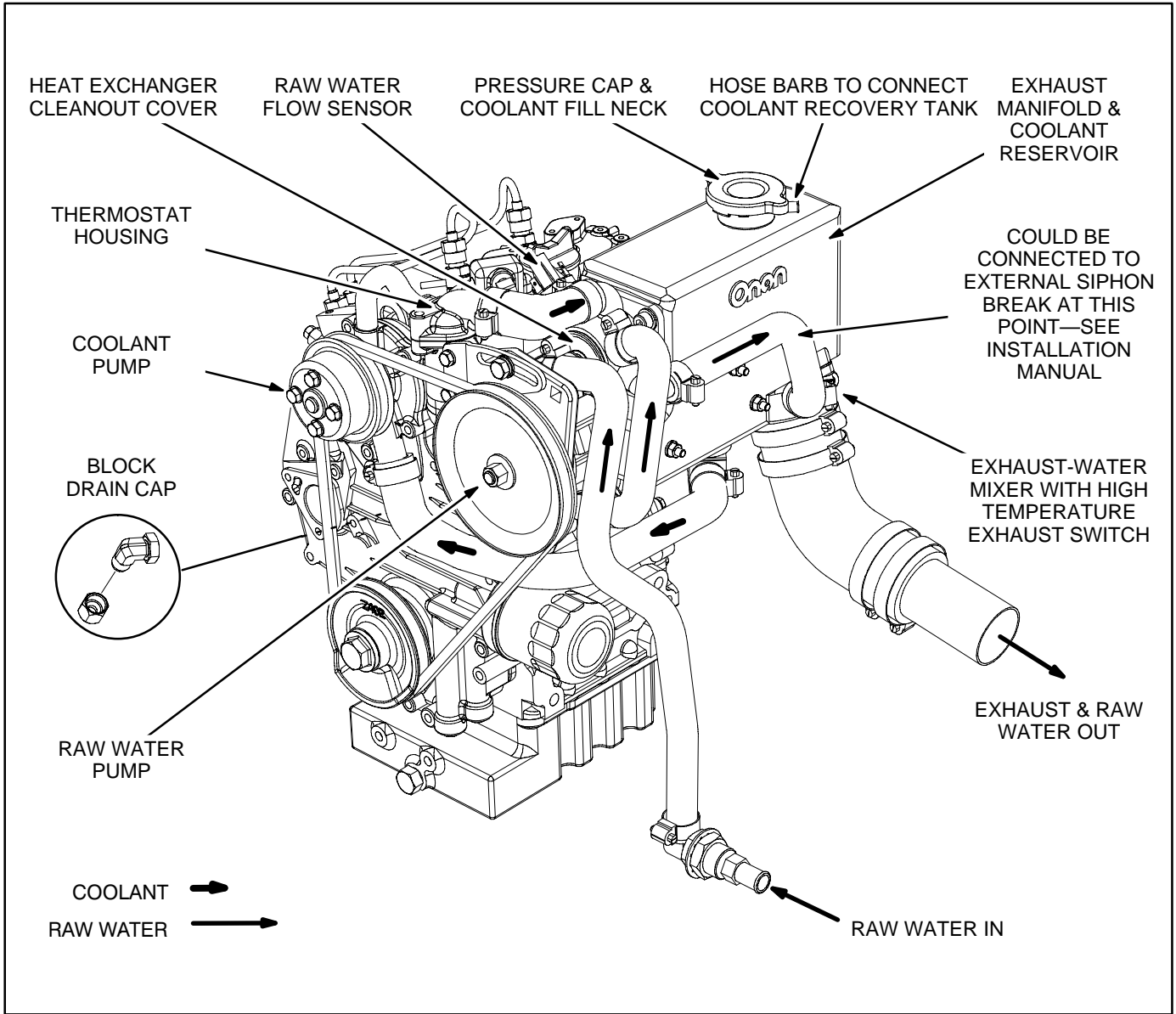

**FIGURE 4-4. ENGINE COOLING SYSTEM**

## Siphon Break

**⚠WARNING** *Bypassing a siphon break or failing to maintain it can lead to engine flooding and damage to the engine not covered under Warranty.*

See Table 4-1 for scheduled maintenance. A siphon break is installed when the exhaust-water mixer is below the water line. If of a spring-loaded valve design, check for free movement of the plunger. Replace the device if the plunger does not move freely or the body is encrusted with deposits from leakage past the valve seat. If of the bleed-vent type, check that the vent hose is properly connected on both ends. If the vent is connected to a through-hull fitting, check for normal water flow whenever the engine is running. See the Installation Manual for more information regarding siphon break installation.

## Replacing the Thermostat

**⚠WARNING** *Accidental or remote starting can cause severe personal injury or death. Disconnect the negative (-) cable from the battery to prevent the engine from starting.*

**Hot coolant spray can cause severe burns. Let the engine cool before releasing the pressure cap or removing the drain cap.**

See Table 4-1 for scheduled replacement. Referring to Figure 4-5, replace the thermostat as follows:

1. Disconnect the negative (-) cable at the battery to prevent the engine from starting, let the engine cool and remove the top access door and pressure cap.
2. Remove the two thermostat housing bolts and pull off the housing, thermostat and gasket. The hose does not need to come off.
3. Clean off the gasket area and install the new thermostat and gasket. Apply Three Bond 1215 liquid sealant or equivalent to the top side of the gasket.
4. Replenish any lost coolant, secure the pressure cap, secure the access door and reconnect the battery cables (negative [-] last).

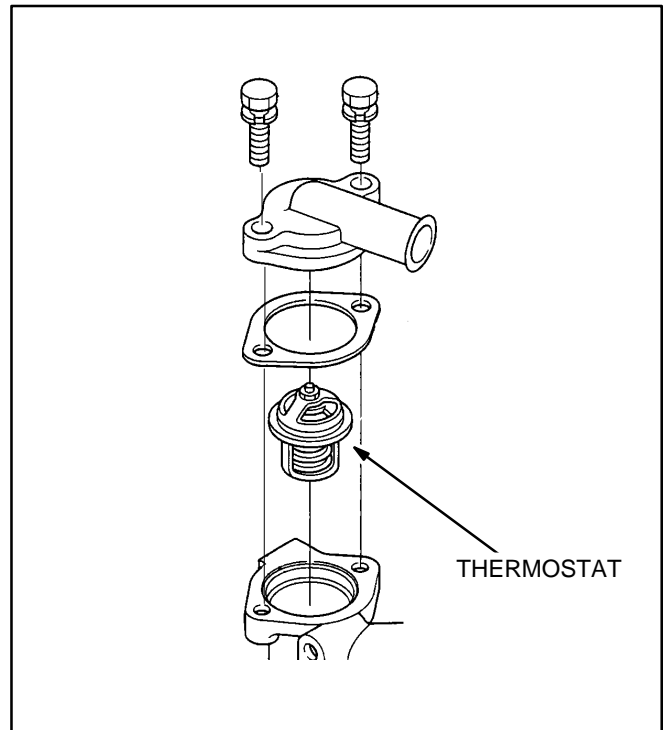

FIGURE 4-5. TYPICAL THERMOSTAT

## Adjusting V-Belt Tension

See Table 4-1 for scheduled inspection or replacement. Adjust belt tension as follows:

1. Disconnect the negative (-) cable at the battery to prevent the engine from starting.

**⚠WARNING** *Accidental or remote starting can cause severe personal injury or death. Disconnect the negative (-) cable at the battery to prevent the engine from starting.*

2. Remove the front and top access doors. If work space is limited, remove the end panel (Figure 4-6) to be able to hold the nut on the pump pivot bolt (Figure 4-7) with an open-end wrench while loosening the bolt.
3. Loosen both bolts so that the pump can pivot.
4. Pivot the pump out to tighten belt tension. Hold tension by tightening the tension adjusting bolt and check it by applying 20 pounds (10 kg) to the middle of the pulley span. Belt tension is correct when deflection is 0.4 inch (10 mm).
5. Tighten the bolts, reassemble the panels and doors and reconnect the battery cables (negative [-] last).

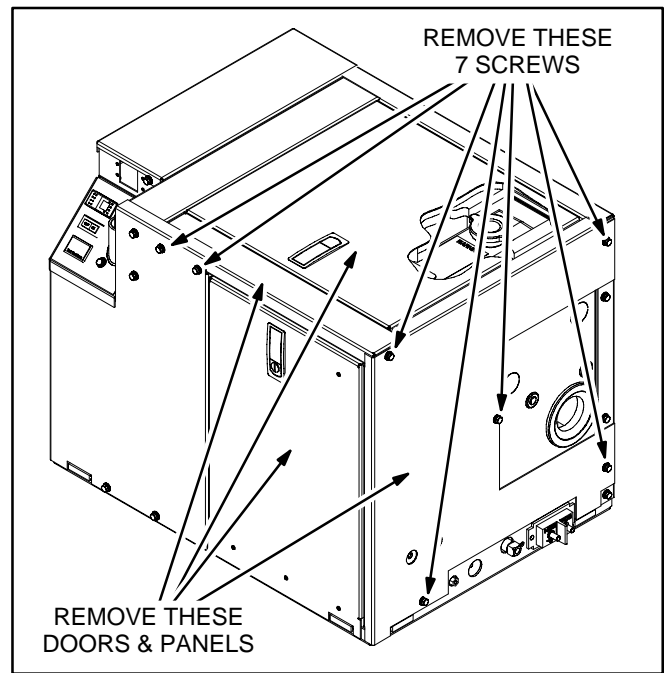

FIGURE 4-6. REMOVING ACCESS PANELS

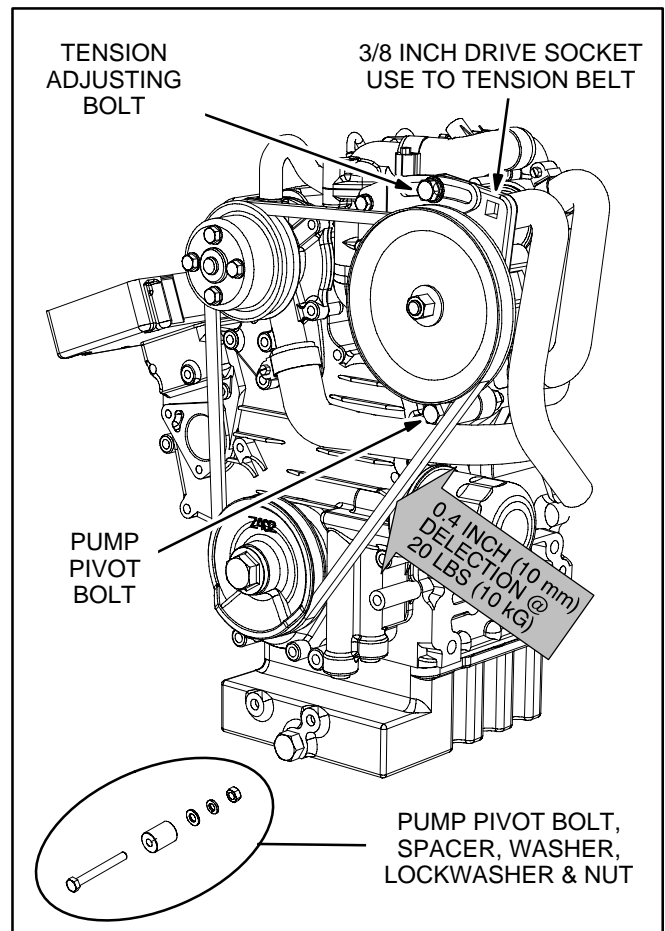

FIGURE 4-7. ADJUSTING V-BELT TENSION

## Replacing the Raw Water Pump Impeller

See Table 4-1 for scheduled replacement. Have towels and containers ready and avoid spilling raw water on the electrical components below the pump. Referring to Figures 4-8 and 4-9, replace the impeller as follows:

1. Close the sea cock.
2. Disconnect the negative (-) cable at the battery to prevent the engine from starting.

**⚠WARNING** *Accidental or remote starting can cause severe personal injury or death. Disconnect the negative (-) cable at the battery to prevent the engine from starting.*

3. Remove the front and top access doors. If work space is limited, remove the end panel (Figure 4-6) to be able to hold the nut on the pump pivot bolt (Figure 4-8) with an open-end wrench while loosening the bolt.
4. Loosen the hose clamps shown in Figure 4-8 and disconnect the hoses.
5. Loosen the two pump mounting bolts and remove the belt. Remove the tension adjusting bolt first and swing the pump out for access to the pivot bolt nut, lock washer and flat washer. Remove the pivot bolt and pull the pump out.

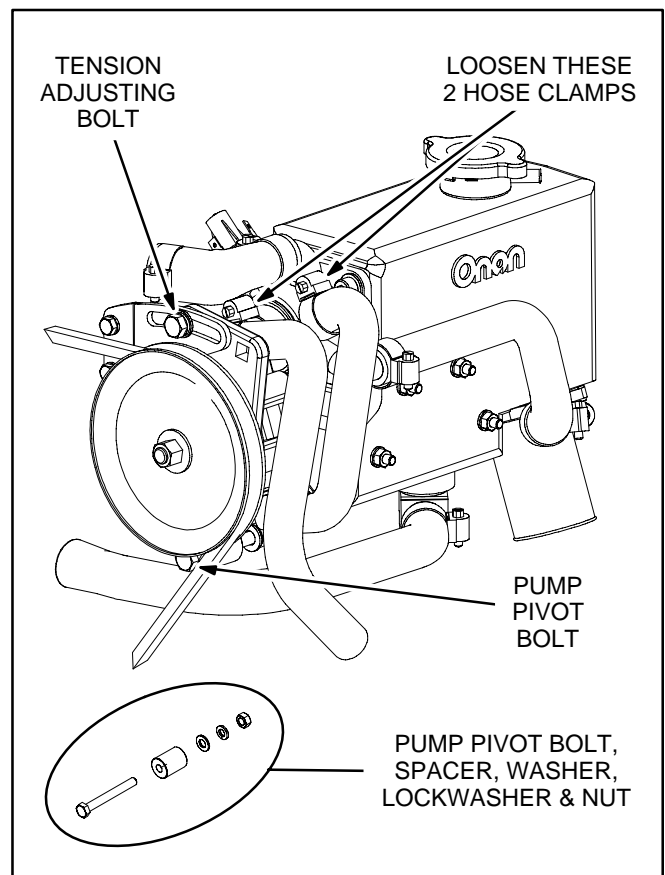
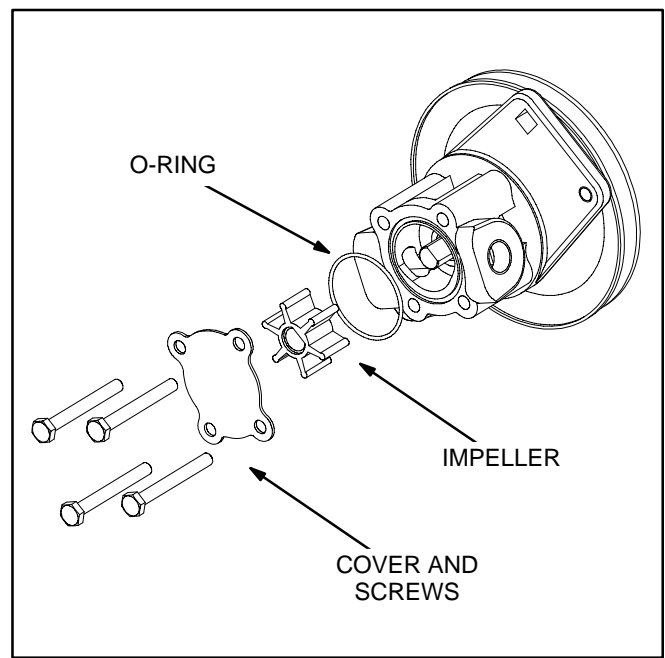

**FIGURE 4-8. REMOVING RAW WATER PUMP**

6. Remove the 4 pump cover screws (Figure 4-9) and remove the impeller and O-ring. Use two pliers to grip vanes on opposite sides if the impeller is difficult to remove. *It will be necessary to check for and cleanout pieces of the impeller from the heat exchanger and exhaust elbow if vanes have broken off.*
7. Install the new impeller. It helps to twist the impeller clockwise (the way it turns) while squeezing it into the housing.
8. To provide initial lubrication and better pump suction before water reaches the pump, wet the inside of the pump and impeller with water, soap solution or a silicone lubricant.

**▲ CAUTION** *Do not lubricate the impeller with grease or oil or other petroleum products because they known to chemically attack impeller materials.*

9. Secure the cover and O-ring.
10. Remount the pump, reconnect the hoses, adjust V-belt tension (Page 4-9) and reassemble the enclosure panels and doors.
11. *Fill the sea water strainer for faster priming at startup if it is above the water line.*
12. Open the sea cock, reconnect the battery cables (negative [-] last) and start the genset. The genset will shut down within 8 seconds if there is no raw water flow and Fault Code No. 7 (p. 5-3) will be declared. If it shuts down, find out why, remove any blockage and restart the genset.



**FIGURE 4-9. REPLACING THE IMPELLER**

## Heat Exchanger

The heat exchanger has a cleanout cover and drain plug (Figure 4-10). Clean the raw water tubes if the engine keeps shutting down (Code No. 1) or the engine gauge indicates abnormally high engine temperatures. Drain the heat exchanger if there is a danger of freezing when the genset is not running or is in storage. (Freezing water can damage the raw water tubes in the heat exchanger. Engine coolant, but not raw water, is protected from freezing.)

**Cleaning and Draining the Heat Exchanger:** To clean the tubes or to drain raw water, first remove the end enclosure panel or the raw water pump (see Replacing the Raw Water Pump Impeller, Page 4-10). Have towels and containers ready to prevent spilling raw water on the electrical components below the heat exchanger.

Remove the drain plug or cleanout cover. Clean and flush the tubes. The drain plug must be removed to get all the water out of the tubes. Do not use metal rods to clean the tubes. The tubes are made of relatively soft copper alloy and can be damaged.

Use thread sealant on the drain plug and a new clean out cover gasket if the old one is torn or otherwise damaged. Reassemble all the parts that were disassembled for access.

**Removing/Installing the Heat Exchanger:** Remove the heat exchanger and have it cleaned at a radiator shop if there is hard scale in the tubes.

To remove the heat exchanger, first disconnect the two leads at the flow sensor, remove the sensor and disconnect the three hoses. (To work the coolant hose elbow off the fitting on the heat exchanger, it will be necessary to loosen the hose clamps on both ends.) Then remove the four mounting bolts and withdraw the heat exchanger.

To install the heat exchanger, first clean the mating gasket faces, taking special care not to scratch the face on the aluminum manifold. Use a new gasket and torque the mounting bolts to 19 lb-ft (26 N-m). Then install the flow sensor using pipe thread sealant and reconnect the two leads in the harness. Reconnect the hoses and reassemble all the parts that were disassembled for access.

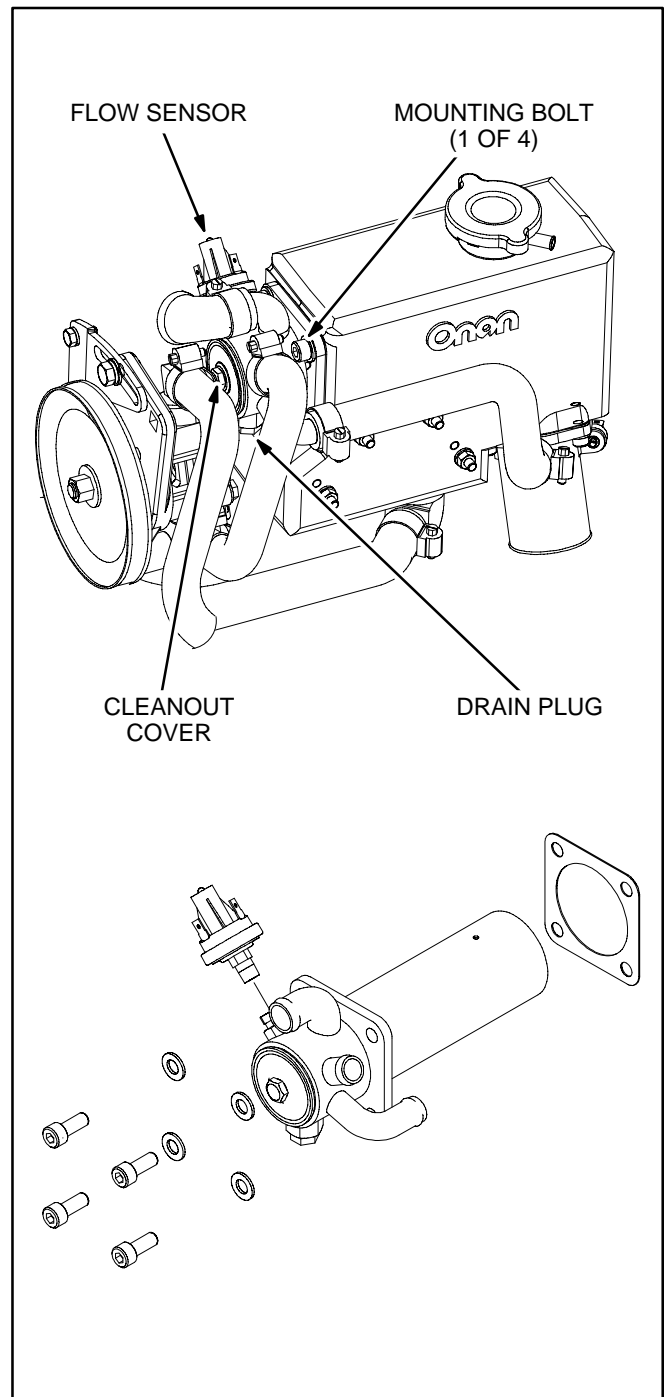

FIGURE 4-10. HEAT EXCHANGER

# 5. Troubleshooting

---

Use TABLE 5-1. TROUBLESHOOTING GENSET FAULTS in conjunction with the e-Series Digital Display or blinking control switch status lamp to troubleshoot the genset. Perform the step-by-step corrective actions suggested. If you are still unable to resolve the problem, contact an authorized Onan service representative. See *How to Obtain Service* (p. 1-2).

Many genset shutdowns can be avoided by performing periodic maintenance on schedule (TABLE 4-1. PERIODIC MAINTENANCE SCHEDULE) and by *not* running the genset out of fuel. Note that when gensets and propulsion engines draw from the same fuel tanks, the fuel dip tubes are usually arranged so that the gensets run out of fuel first. By marking the genset empty points on the fuel gauges, it will be easier to tell when to stop the gensets before running them out of fuel.

## TROUBLESHOOTING WITH DIGITAL DISPLAY

If a fault shutdown occurs the ALARM status lamp on the e-Series Digital Display will blink and the LCD screen will display the Fault Number, a description of the Fault and the hour in total genset running time when the Fault occurred (Figure 2-4).

The fault will be displayed indefinitely. Touch any button to clear the fault. The display will turn off in 5 minutes after the fault has been cleared.

**Last Five Faults:** See Page 2-5 to display any of the last five faults in fault history.

## TROUBLESHOOTING WITH STATUS LAMP

If a fault shutdown occurs, the amber status lamp on the control switch will repeatedly blink sets of 3, 4, 5 or 7 blinks.

- **One blink** indicates shutdown due to high engine temperature.
- **Two blinks** indicate shutdown due to low oil pressure.
- **Three blinks** indicate a service fault. Press **Stop** once to cause the two-digit shutdown code to blink. (Pressing **Stop** again will stop the blinking.) The two-digit code consists of 1 to 7 blinks, a brief pause, and then 1 to 9 blinks. The first set of blinks represents the tens digit and the second set of blinks the units digit of the shutdown code number. For example, **shutdown code No. 36** appears as:

blink-blink-blink—*pause*—blink-blink-blink-blink-blink-blink—  
*long pause*—repeat

- **Four blinks** indicate shutdown due to a failure to start within the time allowed for cranking.
- **Five blinks** indicate shutdown due to high levels of Carbon Monoxide (CO) in the vessel.
- **Seven blinks** indicate shutdown due to a loss of raw water flow for engine and exhaust cooling.

The fault code stops blinking after five minutes. Press **Stop** three times within three seconds to restore fault code blinking.

**Note:** The last fault logged will blink even though the condition that caused the shutdown may have been corrected.

TABLE 5-1. TROUBLESHOOTING GENSET FAULTS

**⚠WARNING** Some genset service procedures present hazards that can result in severe personal injury or death. Only trained and experienced service personnel with knowledge of fuels, electricity, and machinery hazards should perform genset service. See Safety Precautions.

*Accidental or remote starting can cause severe personal injury or death. Before removing a panel or access door, disconnect the negative (-) cable from the battery to prevent the engine from starting.*

**NO RESPONSE AT DIGITAL DISPLAY OR CONTROL SWITCH**

(Faulty switch, poor or missing connections, dead battery)

**Corrective Action:**

1. At the genset control panel, push the emergency stop switch On.
2. Try the Digital Display or control switch on the genset (local) if there is no response at the remote Display or control switch, and vice versa.
3. Check for battery voltage at the battery cable terminals on the genset. Service as necessary by cleaning and tightening battery cable connections, recharging or replacing the battery or replacing damaged or missing battery cables (p. 4-2).

**THE STARTER ENGAGES AND DISENGAGES**

(Low cranking voltage)

**Corrective Action:** Service as necessary by cleaning and tightening battery cable connections, recharging or replacing the battery or replacing damaged battery cables (p. 4-2).

**THE STARTING BATTERIES DO NOT MAINTAIN A CHARGE**

(Marginal battery, battery connections or charging system)

**Corrective Action:**

1. Service the battery as necessary by cleaning and tightening connections, recharging or replacing the battery or replacing damaged battery cables (p. 4-2).
2. Inspect the serpentine belt that drives the charging alternator and service as necessary (p. 4-9).

**NO AC POWER WHEN GENSET IS RUNNING**

(A Circuit Breaker is OFF, tripped or malfunctioning or the generator is not connected properly)

**Corrective Action:**

1. Reset or turn ON the genset circuit breaker if OFF or tripped.
2. Reset or turn ON any other circuit breaker in the AC power supply system if OFF or tripped.

**HIGH ENGINE TEMPERATURE—CODE NO. 1**

(Engine coolant temperature exceed design limit)

**Corrective Action:**

1. Check for and clean a blocked sea water strainer. If above the water line, fill the strainer with water to assist priming.
2. Check engine coolant level and add coolant as necessary.
3. Check for kinked or leaking hoses and reconnect, reroute or replace.
4. Check the V-belt that drives the coolant pump and service as necessary (p. 4-9).
5. Inspect the siphon break (if provided) for proper operation.
6. Check for a worn raw water impeller and replace as necessary (p. 4-10).
7. Clean the heat exchanger (p. 4-12).
8. Check the bottom of the hull for any blockage at the through-hull fitting.

TABLE 5-1. TROUBLESHOOTING GENSET FAULTS (CONT.)

**⚠WARNING** Some genset service procedures present hazards that can result in severe personal injury or death. Only trained and experienced service personnel with knowledge of fuels, electricity, and machinery hazards should perform genset service. See Safety Precautions.

Accidental or remote starting can cause severe personal injury or death. Before removing a panel or access door, disconnect the negative (–) cable from the battery to prevent the engine from starting.

**LOW OIL PRESSURE—CODE NO. 2**

(Low oil pressure)

**Corrective Action:** Check engine oil level, add or drain oil as necessary and repair any leaks (p. 4-3).

**SERVICE CHECK—CODE NO. 3**

(A fault with a 2-Digit Fault Code Number occurred)

**Corrective Action:** Check the 2-Digit fault code by *Pushing* and *Releasing Stop*. The 2-Digit fault will be one of the following in this table. (Does not apply to e-Series Digital Display.)

**OVERCRANK—CODE NO. 4**

(Cranking time exceeded 20 to 60 seconds, depending on ambient temperature)

**Corrective Action:**

1. Check fuel level and refill as necessary. (Note: The genset fuel pickups are probably higher than the propulsion engine fuel pickups.)
2. Open any closed fuel supply and return valves.
3. Prime the engine fuel system for at least 30 seconds (p. 3-3).
4. Service the battery as necessary by cleaning and tightening connections, recharging or replacing the battery or replacing damaged battery cables (p. 4-2).
5. Replace the fuel filters and reprime (p. 4-5).
6. Check all fuel fittings for fuel and air leaks, tighten as necessary and reprime.
7. Change the engine oil to oil of the proper viscosity for the ambient temperature. High oil viscosity can slow down cranking speed.

**WARNING—SHUTDOWN DUE TO VESSEL CO—CODE NO. 5**

(Dangerous levels of Carbon Monoxide in Vessel)

**Corrective Action:** Get everyone out into fresh air immediately and seek medical attention.

**LOSS OF RAW WATER FLOW—CODE NO. 7**

(Low raw water pressure in heat exchanger)

**Corrective Action:**

1. Open the sea cock.
2. Check for and clean a blocked sea water strainer. If above the water line, fill the strainer with water to assist priming.
3. Check for kinked or leaking hoses and reconnect, reroute or replace.
4. Check for a worn raw water impeller and replace as necessary (p. 4-10).
5. Check the bottom of the hull for any blockage at the through-hull fitting.

TABLE 5-1. TROUBLESHOOTING GENSET FAULTS (CONT.)

**⚠WARNING** *Some genset service procedures present hazards that can result in severe personal injury or death. Only trained and experienced service personnel with knowledge of fuels, electricity, and machinery hazards should perform genset service. See Safety Precautions.*

*Accidental or remote starting can cause severe personal injury or death. Before removing a panel or access door, disconnect the negative (-) cable from the battery to prevent the engine from starting.*

**HIGH AC VOLTAGE—CODE NO. 12**

(After voltage regulation was enabled Output Voltage jumped to more than 125% of rated for 75 milliseconds or to more than 115% of rated for 3 seconds)

**Corrective Action:** See an authorized Onan service representative.

**LOW AC VOLTAGE—CODE NO. 13**

(After voltage regulation was enabled Output Voltage fell to less than 90% of rated for 5 seconds)

**Corrective Action:** Push the genset line circuit breaker OFF. If the genset now runs, reduce the number of loads.

**HIGH AC FREQUENCY—CODE NO. 14**

(After the starter was engaged Frequency jumped to more than 70 Hz for 40 milliseconds or to more than 2% over nominal for 6 seconds)

**Corrective Action:**

1. Check for a tripped genset circuit breaker, reset it if necessary, and run with fewer connected loads . (A breaker tripping under load can cause genset frequency to overshoot.)
2. Check all fuel fittings for fuel and air leaks and tighten as necessary and reprime. (Air bubbles can disrupt frequency.)

**LOW AC FREQUENCY—CODE NO. 15**

(During normal operation Frequency fell to less than 90% of nominal for more than 8 seconds)

**Corrective Action:**

1. Push the genset line circuit breaker OFF. If the genset now runs, reduce the number of loads, especially those with high motor starting loads such as air conditioners.
2. Check fuel level and fill as necessary.
3. Prime the engine fuel system for at least 30 seconds (p. 3-3).
4. Check all fuel fittings for fuel and air leaks, tighten as necessary and reprime. (Air bubbles can disrupt frequency.)
5. Replace the fuel filters and reprime (p. 4-5).

**GOVERNOR OVERLOAD—CODE NO. 22**

(Maximum allowable time at full-duty cycle was exceeded)

**Corrective Action:**

1. Reduce the number of appliances running at the same time, especially those with high motor starting loads such as air conditioners.
2. Check the fuel tank and fill as necessary. (Note: The arrangement of pickup tubes in the fuel supply tank probably is such that the genset will run out of fuel before the propulsion engines.)
3. Remove any blockage in the combustion air inlet (front grille) or exhaust system.
4. Check all fuel fittings for fuel and air leaks, tighten as necessary and reprime.
5. Replace the fuel filters and reprime (p. 4-5).

TABLE 5-1. TROUBLESHOOTING GENSET FAULTS (CONT.)

**⚠WARNING** *Some genset service procedures present hazards that can result in severe personal injury or death. Only trained and experienced service personnel with knowledge of fuels, electricity, and machinery hazards should perform genset service. See Safety Precautions.*

*Accidental or remote starting can cause severe personal injury or death. Before removing a panel or access door, disconnect the negative (-) cable from the battery to prevent the engine from starting.*

**FAULTY OIL PRESSURE SENDER—CODE NO. 23**

(Controller sensed grounded sender)

**Corrective Action:** See an authorized Onan service representative.

**FAULTY TEMPERATURE SENDER—CODE NO. 24**

(Controller sensed open sender)

**Corrective Action:** See an authorized Onan service representative.

**LOSS OF AC VOLTAGE SENSE—CODE NO. 27**

(The genset Controller lost VAC sensing during normal voltage regulation when the field was functioning normally and frequency was at least 40 Hz)

**Corrective Action:** See an authorized Onan service representative.

**HIGH BATTERY VOLTAGE—CODE NO. 29**

(During startup the genset Controller sensed that battery system voltage was greater than 19.2 volts)

**Corrective Action:**

1. Check battery bank connections and reconnect if necessary for 12 volts.
2. Select a lower battery booster charge rate.

**STARTING FAULT—CODE NO. 32**

(The genset Controller could not detect cranking speed [quadrature zero crossings] for 3 seconds)

**Corrective Action:**

1. Have the propulsion engines running while trying to start the genset. Their charging alternators may be able to maintain a high enough battery terminal voltage to start the genset.
2. Service the battery as necessary by cleaning and tightening connections, recharging or replacing the battery or replacing damaged battery cables (p. 4-2).
3. Change the engine oil to oil of the proper viscosity for the ambient temperature. High oil viscosity can slow down cranking speed.

**CONTROL CARD FAILURE—EE—CODE NO. 35**

(During startup the genset Controller detected a EE memory error)

**Corrective Action:** See an authorized Onan service representative.

TABLE 5-1. TROUBLESHOOTING GENSET FAULTS (CONT.)

**⚠WARNING** *Some genset service procedures present hazards that can result in severe personal injury or death. Only trained and experienced service personnel with knowledge of fuels, electricity, and machinery hazards should perform genset service. See Safety Precautions.*

*Accidental or remote starting can cause severe personal injury or death. Before removing a panel or access door, disconnect the negative (-) cable from the battery to prevent the engine from starting.*

**UNKNOWN SHUTDOWN—CODE NO. 36**

(The genset Controller declared this fault because engine speed fell below 1000 RPM for 0.5 seconds, though not by genset or engine control action)

**Corrective Action:**

1. Reduce the number of loads on the genset.
2. Check fuel level and refill as necessary. (Note: The genset fuel pickups are probably higher than the propulsion engine fuel pickups.)
3. Prime the engine fuel system for at least 30 seconds (p. 3-3).
4. Check all fuel fittings for fuel and air leaks, tighten as necessary and reprime.
5. Replace the fuel filters and reprime (p. 4-5).

**INVALID GENSET CONFIGURATION—CODE NO. 37**

(The genset Controller is not configured properly for the genset )

**Corrective Action:** See an authorized Onan service representative.

**FIELD OVERLOAD—CODE NO. 38**

(High field voltage induced by high rotor temperature or low power factor loads)

**Corrective Action:**

1. Remove blockages to generator air flow at the front inlet grill and right side, if enclosed.
2. Reduce the number of appliances running at the same time, especially those with high motor starting loads such as air conditioners.
3. Have air conditioners and other appliances checked for proper operation. (A locked compressor rotor can cause very low power factor.)

**CONTROL CARD FAILURE—RAM—CODE NO. 43**

(During startup the genset Controller detected a RAM memory error)

**Corrective Action:** See an authorized Onan service representative.

**SPEED SENSE LOST—CODE NO. 45**

(After start disconnect the genset Controller lost speed sense [quadrature zero crossings] for 0.25 seconds)

**Corrective Action:** See an authorized Onan service representative.

**GENSET OVERLOAD—CODE NO. 46**

(The genset Controller shutdown the genset because engine load exceeded 135 percent of genset rating for 10 seconds)

**Corrective Action:** Reduce the number of loads on the genset.

TABLE 5-1. TROUBLESHOOTING GENSET FAULTS (CONT.)

**⚠WARNING** *Some genset service procedures present hazards that can result in severe personal injury or death. Only trained and experienced service personnel with knowledge of fuels, electricity, and machinery hazards should perform genset service. See Safety Precautions.*

*Accidental or remote starting can cause severe personal injury or death. Before removing a panel or access door, disconnect the negative (–) cable from the battery to prevent the engine from starting.*

**OVERPRIME—CODE NO. 57**

(A local or remote control switch was held in the Prime position for more than 5 minutes)

**Corrective Action:** Check for and remove any object that may be holding either control switch (remote or local) in the prime position.

**HIGH EXHAUST TEMPERATURE—CODE NO. 58**

(Exhaust temperature exceeded design limits due to lack of water delivered to the exhaust/water mixer)

**Corrective Action:**

1. Check for and clean a blocked sea water strainer. If above the water line, fill the strainer with water to assist priming.
2. Check for kinked or leaking hoses and reconnect, reroute or replace.
3. Inspect the siphon break (if provided) for proper operation.
4. Check for a worn raw water impeller and replace as necessary (p. 4-10).
5. Clean the heat exchanger (p. 4-12).

**EXTERNAL SHUTDOWN—CODE NO. 61**

(Genset was shut down by a fire suppression system or other external control)

**Corrective Action:** Make all necessary repairs to the genset and connected equipment and reset the external control which shut down the genset.



## 6. Specifications

<b>GENERATOR:</b> Two-Bearing, 2-Pole Rotating Field, Microprocessor Regulated. See Genset Nameplate for Rating		
<b>FUEL CONSUMPTION:</b>		
60 Hz:	Full Load Half Load	0.60 gph (2.3 liter/hr) 0.35 gph (1.3 liter/hr)
50 Hz:	Full Load Half Load	0.50 gph (1.9 liter/hr) 0.29 gph (1.1 liter/hr)
Engine/Generator Speed:	60 Hz 50 Hz	2900/3600 rpm 2400/3000 rpm
<b>ENGINE:</b> 4-Stroke Cycle, Indirect Injection Diesel, Water Cooled, Microprocessor Governed (Isochronous)		
Number of Cylinders		2
Bore		2.52 inch (64 mm)
Stroke		2.45 inch (62.2 mm)
Displacement		24.41 inch <sup>3</sup> (400 cm <sup>3</sup> )
Compression Ratio		23:1
Firing Order (Clockwise Rotation)		1-2
Fuel Injection Timing		18° – 20° BTDC
Fuel Injection Pressure		1991 psi (13.73 MPa)
Valve Lash (cold)		0.0059 – 0.0073 INCH (0.145 – 0.185 MM)
Engine Oil Capacity		2.2 quart (2.1 liter)
Engine Oil Drain Connection		3/8 NPT
Coolant Capacity		2.2 quart (2.1 liter)
Coolant Flow:	60 Hz 50 Hz	3.5 gpm (13 liter/min) 3.0 gpm (16 liter/min)
Raw Water Flow:	60 Hz 50 Hz	5.0 gpm (19 liter/min) 4.0 gpm (15 liter/min)
Maximum Raw Water Pump Lift		4 feet (1.2 m) with 5/8 inch ID hose
Raw Water Inlet Connection		5/8 inch (15.9 mm) ID Hose
Maximum Fuel Pump Lift		4 feet (1.2 m) with 3/8 inch ID fuel line
Recommended Fuel Line Size		3/8 inch (9 mm) ID
Fuel Supply Connection		1/8 NPT female
Fuel Return Connection		1/8 NPT female
Maximum Exhaust Back Pressure		3 INCH (76 MM) HG
Wet Exhaust Outlet Connection		2.0 INCH (50.8 MM) ID HOSE
Combustion Air		18 CFM (30 M <sup>3</sup> /HR)
Generator Cooling Air		60-80 CFM (100-135 M <sup>3</sup> /HR)
<b>BATTERIES:</b>		
Nominal Battery Voltage		12 volts
Minimum CCA Rating		360 amps
Battery Charging Output		Trickle (3 amps)
<b>SIZE, WEIGHT, NOISE:</b>		
Size: L x W x H		26 x 20.1 x 20.6 inch (662 x 511 x 524 mm)
Weight (dry)		350 lbs (159 kg)
Noise:	60 Hz 50 Hz	71 dB(A) 68 dB(A)





